

TECHNICAL MANUAL

OPERATOR'S AND UNIT  
MAINTENANCE MANUAL  
(INCLUDING REPAIR PARTS  
AND SPECIAL TOOLS LIST)  
FOR

ULTRALIGHTWEIGHT  
CAMOUFLAGE NET SYSTEMS  
(ULCANS)

WOODLAND R/S AN/USQ-150  
(NSN 1080-01-457-2956) (EIC: N/A)

WOODLAND R/T AN/USQ-160  
(NSN 1080-01-475-0697) (EIC: N/A)

DESERT R/S AN/USQ-159  
(NSN 1080-01-475-0696) (EIC: N/A)

DESERT R/T AN/USQ-158  
(NSN 1080-01-475-0694) (EIC: (N/A))



INTRODUCTION

OPERATING  
INSTRUCTIONS

MAINTENANCE  
INSTRUCTIONS

REFERENCES

MAINTENANCE  
ALLOCATION CHART

REPAIR PARTS AND SPECIAL  
TOOLS LIST

COMPONENTS OF END ITEM  
BASIC ISSUE ITEMS

ADDITIONAL AUTHORIZATION  
LIST

EXPENDABLE AND DURABLE  
ITEMS LIST

Approved for Public Release; Distribution is Unlimited

HEADQUARTERS, DEPARTMENT OF THE ARMY

1 January 2003

## SAFETY SUMMARY

The following are general safety precautions and instructions that people must understand and apply during phases of operation and maintenance. Proper adherence to these instructions will ensure personal safety and the protection of property.

Trichlorotrifluoroethane, trichloroethane and similar chemical solvents shall no longer be used for ordinary cleaning of equipment. These substances threaten public health and the environment by destroying ozone in the earth's upper atmosphere. Suitable non-hazardous cleaning materials will be used instead, such as a clean cloth, water and mild detergents.

### WARNING AND CAUTION STATEMENTS

WARNING and CAUTION statements will appear prior to operation and maintenance procedures, practices, or conditions considered essential to the protection of personnel (WARNING) or equipment and property (CAUTION). A WARNING or CAUTION will apply each time the related step is repeated. Prior to starting any task, the WARNING and CAUTIONS included in the text for that task shall be reviewed and understood.

#### WARNING

To prevent personal injury, a minimum of a "two-person" lift is required for both the ULCANS screen system and the support system storage/transport containers. Components may increase in weight due to trapped or absorbed water. Use additional personnel as needed.

#### WARNING

To prevent personal injury, secure dog tags, remove jewelry, individual equipment, and clothing items that can become snagged during deployment or striking of ULCANS screens. Failure to observe this warning can result in severe injury, loss of limb, or death from falling.

#### WARNING

Volatile fuels and vehicle exhaust can create a fire hazard and can cause explosions. These hazards are always present but most prevalent during hot weather. When volatile fuels or vehicle exhaust are present under ULCANS, steps will be undertaken to insure adequate ventilation of the camouflaged area.

#### WARNING

Support poles will conduct electricity. To prevent electrical shock, do not allow support poles to contact sources of electricity during deployment or retrieval.

**WARNING**

Personnel are subject to being burned by hot components and exhausts if deployment of the ULCANS is attempted with the equipment's engine running or immediately after the engine is turned off. A cool down period shall be observed prior to ULCANS deployment except in emergency conditions; then wear hand protection and exercise extreme caution when working in area of hot components.

**WARNING**

Climbing on and around the equipment to deploy ULCANS can pose a fall hazard. Extreme caution shall be observed to avoid slippery or uneven surfaces and other trip hazards. Use handhold when provided and ladders when available.

**WARNING**

Particles of dirt and debris carried by netting/garnish can be scraped off and fall into the operator's eyes when looking upward during setup and takedown of ULCANS. Eye protection is required during setup and takedown operations of ULCANS.

**WARNING**

Combustion by-products of ULCANS can be toxic. Evacuate the area and stay out of the path of smoke if ULCANS systems are exposed to fire. Self-contained breathing apparatus is required when fighting ULCANS fire.

**WARNING**

The radar scattering ULCANS must not be placed over active radar equipment because it will seriously interfere with the operation of radar equipment underneath it.

**WARNING**

ULCANS stakes may present a trip hazard. Drive stakes deeply to minimize area protruding above ground. Select an area without stakes for entry/egress through the screen.

**CAUTION**

Proper identification of screens must be maintained at all times. Do not remove or lose identification tags that are attached to screens. Do not use a transparent screen in place of a radar scattering screen. When two or more screens are joined together, ensure that the screens are of the same type by checking each screens' identification tag.

**CAUTION**

Keep screens away from all hot exhaust systems. (Includes vehicles, heaters, stoves, etc.) Screens can be damaged if not struck and removed from back blast area of field artillery prior to firing.

**CAUTION**

When using an ULCANS multi-screen configuration of 8 ft high or more, camouflage screens can be blown down when winds exceed 46 miles per hour. Damage to equipment may result. When winds in excess of 46 miles per hour are expected, screens will be lowered and secured.

**CAUTION**

Use only the ULCANS fabric of the same type and class as the ULCANS that is being repaired.

**CAUTION**

It is recommended that gloves be worn at all times when working with ULCANS. The gripping surface of the shape disruptor can cause skin abrasions.

**CAUTION**

In desert environments, the support poles and metal stakes left in direct sunlight can become extremely hot to touch. Wear gloves to prevent burns

**CAUTION**

When using lengths of rope to make a repair, ensure cut ends are heat sealed prior to use.

Change

No. 1

Headquarters,  
Department of the Army  
Washington, DC, 1 August 2008

**Operator's and Unit Maintenance Manual  
(Including Repair Parts and Special Tools List)**

**For**

**ULTRALIGHTWEIGHT CAMOUFLAGE NET SYSTEMS  
(ULCANS)**

**WOODLAND R/S AN/USQ-150 (NSN 1080-01-457-2956) (EIC: N/A)**

**WOODLAND R/T AN/USQ-160 (NSN 1080-01-475-0697) (EIC: N/A)**

**DESERT R/S AN/USQ-159 (NSN 1080-01-475-0696) (EIC: N/A)**

**DESERT R/T AN/USQ-158 (NSN 1080-01-475-0694) (EIC: (N/A)**

**REPORTING ERRORS AND RECOMMENDING IMPROVEMENTS**

You can help improve this manual. If you find any mistakes or if you know of a way to improve the procedures, please let us know. Reports, as applicable by the requiring Service, should be submitted as follows:

Mail your letter or DA Form 2028 (Recommended Changes to Publications and Blank Forms) located in the back of this manual, directly to: Commander, U.S. Army CECOM Life Cycle Management Command (LCMC) and Fort Monmouth, ATTN: AMSEL-LC-LEO-E-ED, Fort Monmouth, NJ 07703-5006. You may also send in your recommended changes via electronic mail or by fax. Our fax number is 732-532-1556, DSN 992-1556. Our e-mail address is [MONM-AMSELLEOPUBSCHG@conus.army.mil](mailto:MONM-AMSELLEOPUBSCHG@conus.army.mil). Our online web address for entering and submitting DA Form 2028s is <http://edm.monmouth.army.mil/pubs/2028.html>.

A reply will be furnished to you.

Approved for Public Release; distribution is unlimited.

TM 5-1080-250-12&P, dated 1 January 2003, is changed as follows:

1. Appendix B., Maintenance Allocation Chart, has been revised to implement Army Maintenance Transformation and changes the Maintenance Allocation Chart (MAC) to support Field and Sustainment Maintenance. Because the entire Appendix is revised, no change bars/hands are used.

*Remove Pages*

C and D  
1-9 through 1-12  
B-1 through B-8

*Insert Pages*

C and D  
1-9 through 1-12  
B-1 through B-10

2. File this change sheet in the front of the publication for reference purposes.

By Order of the Secretary of the Army:

GEORGE W. CASEY, JR  
*General, United States Army*  
*Chief of Staff*

Official:



JOYCE E. MORROW  
*Administrative Assistant to the*  
*Secretary of the Army*  
0816901

DISTRIBUTION:

To be distributed in accordance with the initial distribution number (IDN) 256761 requirements for TM 5-1050-250-12&P.

**LIST OF EFFECTIVE PAGES**

INSERT LATEST CHANGED PAGES. DESTROY SUPERSEDED PAGES

Dates of issue for original and changed pages are:

Original ..... 1 January 2003

Change 1 ..... 1 August 2008

TOTAL NUMBER OF PAGES IN THIS PUBLICATION IS 106  
CONSISTING OF THE FOLLOWING:

Page	*Change No.
Cover.....	0
Warnings (A through C) .....	0
<b>Warnings (D) .....</b>	<b>1</b>
i through v/(vi Blank) .....	0
1-1 through 1-9.....	0
<b>1-10 and 1-11 .....</b>	<b>1</b>
1-12 .....	0
2-1 through 2-19/(2-20 Blank).....	0
3-1 through 3-4.....	0
A-1/(A-2 Blank).....	0
<b>B-1 through B-10 .....</b>	<b>1</b>
C-1 through C-6/(C-7 Blank) .....	0
C-8 through C-15/(C-16 Blank) .....	0
C-17 and C-18.....	0
D-1 through D-6 .....	0
E-1 and E-2 .....	0
F-1/(F-2 Blank) .....	0
Glossary-1 and Glossary-2 .....	0
Index-1 and Index-2 .....	0

\* Zero in this column indicates an original page.

USA

**Operator's and Unit Maintenance Manual  
(Including Repair Parts and Special Tools List)**

**For**

**ULTRALIGHTWEIGHT CAMOUFLAGE NET SYSTEMS  
(ULCANS)**

**WOODLAND R/S AN/USQ-150 (NSN 1080-01-457-2956) (EIC: N/A)**

**WOODLAND R/T AN/USQ-160 (NSN 1080-01-475-0697) (EIC: N/A)**

**DESERT R/S AN/USQ-159 (NSN 1080-01-475-0696) (EIC: N/A)**

**DESERT R/T AN/USQ-158 (NSN 1080-01-475-0694) (EIC: (N/A)**

*Current as of: 1 September 2002*

**REPORTING ERRORS AND RECOMMENDING IMPROVEMENTS**

You can help improve this manual. If you find any mistakes, or if you know of any way to improve the procedures, please let us know. Mail your letter, DA Form 2028 (Recommended Changes to Publications and Blank Forms) or DA Form 2028-2 located in back of this manual direct to: Commander, US Army Communications-Electronics Command and Fort Monmouth, ATTN: AMSEL-LC-LEO-D-CS-CFO, Fort Monmouth, New Jersey 07703-5006. The fax number is 732-532-1413, DSN 992-1413. You may also e-mail recommendations to [AMSEL-LC-LEO-PUBS-CHG@cecom3.monmouth.army.mil](mailto:AMSEL-LC-LEO-PUBS-CHG@cecom3.monmouth.army.mil).

We will furnish you a reply.

**TABLE OF CONTENTS**

	<b>Page</b>
How To Use This Manual .....	v
<b>CHAPTER 1 INTRODUCTION.....</b>	<b>1-1</b>
Section I General.....	1-1
1-1 Scope.....	1-1
1-2 Purpose of Equipment.....	1-1
1-3 Consolidated Index of Army Publications and Blank Forms.....	1-1
1-4 Maintenance Forms, Records, and Reports .....	1-1
1-5 Reporting Equipment Improvement Recommendations (EIR) .....	1-2
1-6 Administrative Storage.....	1-2
1-7 Destruction to Prevent Enemy Use.....	1-2
Section II Equipment Description, Characteristics and Equipment Data.....	1-2
1-8 Equipment Description .....	1-2
a. Modular Camouflage Screen System .....	1-2
b. Repair Kit.....	1-2
c. Support System.....	1-3
d. Shape Disrupter Assemblies .....	1-3
1-9 ULCANS Applications and Configuration Data .....	1-3
1-10 Module Determination Chart.....	1-8



TABLE OF CONTENTS - Continued

	<b>Page</b>
1-11 Tabulated Data.....	1-10
1-12 Classification, Camouflage Screening Types, and Class.....	1-11
<b>CHAPTER 2</b>	
<b>OPERATING INSTRUCTIONS.....</b>	<b>2-1</b>
Section I	
Operation Under Normal Conditions .....	2-1
2-1 General.....	2-1
Section II	
ULCANS Deployment/Retrieval Instructions .....	2-1
2-2 Deployment Instructions .....	2-1
a. ULCANS Deployment.....	2-2
b. Cool Down Period .....	2-2
c. Multiple Screen Assembly .....	2-3
d. Shape Disruption.....	2-3
e. Support Poles .....	2-13
f. Positioning Support Poles .....	2-13
g. Stakes.....	2-14
h. Special Assembly Instructions .....	2-14
i. Volatile Fuels and Hazardous Materials .....	2-15
j. Deployment Checks .....	2-15
k. ULCANS Entry/Egress Doorway.....	2-15
2-3 Retrieval Instructions, Multiple Screen Configuration .....	2-16
a. Normal Retrieval.....	2-16
b. Folding Instructions, ULCANS.....	2-16
c. Roll Method For Multiple Screens.....	2-17
d. Special Tools .....	2-17
Section III	
Operation Under Unusual Conditions .....	2-18
2-4 Operating Under Unusual Conditions .....	2-18
a. Inclement Weather .....	2-18
b. Emergency Retrieval.....	2-18
<b>CHAPTER 3</b>	
<b>MAINTENANCE INSTRUCTIONS .....</b>	<b>3-1</b>
Section I	
Maintenance Requirements .....	3-1
3-1 Repair Requirements.....	3-1
Section II	
Maintenance Procedures .....	3-1
3-2 Screen Maintenance Procedures .....	3-1

**TABLE OF CONTENTS - Continued**

APPENDIX A	REFERENCES .....	A-1	<b>Page</b>
APPENDIX B	MAINTENANCE ALLOCATION CHART .....	B-1	
APPENDIX C	REPAIR PARTS AND SPECIAL TOOLS LIST .....	C-1	
			<b>Illus/ Figure</b>
			<b>Page</b>
Group 00	ULCANS (Class 1 - Woodland and Class 2 - Desert; Type IV (Gp-R/S) and Type III (Gp R/T))	C-1	C-8
01	Camouflage Screening System .....	C-2	C-10
0101	Screen, Camouflage (Hexagon) (No Parts Authorized)		
0102	Screen, Camouflage (Rhombic) (No Parts Authorized)		
02	Support, Camouflage Screening System .....	C-3	C-12
0103	Repair Kit, Camouflage Net Set.....	C-4	C-14
APPENDIX D	COMPONENTS OF END ITEM AND BASIC ISSUE ITEMS LIST .....	D-1	
APPENDIX E	ADDITIONAL AUTHORIZATION LIST .....	E-1	
APPENDIX F	EXPENDABLE AND DURABLE ITEMS LIST.....	F-1	
Glossary.....		Glossary-1	
Index.....		Index-1	

**LIST OF ILLUSTRATIONS**

Figure	Title	Page
1-1	Ultralightweight Camouflage Net Systems (ULCANS).....	1-1
1-2	ULCANS Components .....	1-3
1-3	Typical ULCANS Applications .....	1-5
1-4	Screen Configuration Data.....	1-7
1-5	Module Determination Chart.....	1-9
1-6	ULCANS Woodland, Type IV Radar Scattering Screen Identification Tag .....	1-13
1-7	ULCANS Radar Transparent Screen Identification Tag.....	1-14
2-1	Multiple Screen Assembly and Disassembly Instructions .....	2-4
2-2	Deployment/Retrieval/Storage Instructions, ULCANS .....	2-5
2-3	Doorway Entrance/Egress.....	2-16
3-1	ULCANS Camouflage Screen Repair .....	3-3
C-1	ULCANS (Class 1 - Woodland and Class 2 - Desert; Type IV (Gp-R/S) and Type III (Gp R/T)) .....	C-8
C-2	Camouflage Screening System .....	C-10
C-3	Support, Camouflage Screening System .....	C-12
C-4	Repair Kit, Camouflage Net Set.....	C-14
D-1	ULCANS Components .....	D-3

LIST OF TABLES

Table	Title	Page
1-1	Screen Configuration Dimensions .....	1-8
1-2	Total System Weight.....	1-11
1-3	Number of Support System Components.....	1-12
1-4	Height of Support Poles.....	1-12

## HOW TO USE THIS MANUAL

This manual is designed to help the user operate and maintain the Ultralightweight Camouflage Net System (ULCANS). Listed below are some of the features included in this manual to help locate and use the provided information.

### NOTE

**Radar Scattering is denoted as R/S**  
**Radar Transparent is denoted as R/T**

- A List of Effective Pages is included to help the user easily identify the latest information that is included in this manual.
- A Table of Contents is provided as a quick reference to the chapters and paragraphs that will be used often.
- Warnings, cautions, notes, and subject headings, as well as other essential information, are printed in bold type to make them easier to see.
- This manual contains exploded view illustrations that will assist the user with initial setup, assembly, and disassembly procedures.
- Chapter 1 provides the user with the description, characteristics, and theory of operation of the ULCANS, and its major components along with configuration instructions.
- Chapter 2 provides operational information with specific deployment and retrieval instructions.
- Chapter 3 describes screen maintenance and repair procedures and gives pole maintenance instructions.
- The Appendixes provide the user with: Identifying references, a Maintenance Allocation Chart (MAC), a Repair Parts and Special Tools List (RPSTL), a Component of End Items List (COEIL), a Basic Issue Items List (BIIL), an Additional Authorization List (AAL), and an Expendable and Durable Items List.
- A Glossary of common terms is also provided.

## CHAPTER 1

### INTRODUCTION

#### Section I. GENERAL

##### 1-1. SCOPE.

This manual is for use when utilizing and maintaining the Ultralightweight Camouflage Net System, General Purpose Woodland, (Class 1) or Desert (Class 2), Radar Transparent, Type III, and Radar Scattering, Type IV, hereafter referred to as ULCANS. See Figure 1-1.

##### 1-2. PURPOSE OF EQUIPMENT.

The ULCANS is designed to improve survivability of military hardware as an all weather modular concealment system that provides visual, near infrared, and radar signature reduction. The screens are made of a synthetic, ultralightweight, water resistant material. It is of snag resistant construction and is field repairable and maintainable. It is designed for easy, rapid deployment and recovery by a minimum of two (four for larger multi-screen setup) experienced soldiers. The service life of ULCANS Woodland or Desert, Type III or IV, is estimated to be 112 deployment and recovery cycles.

#### NOTE

ULCANS Radar Transparent (R/T) Type III will be used for general purpose concealment of ground radar equipment.

ULCANS Radar Scattering (R/S) Type IV will be used for general purpose concealment of ground non-radar equipment.

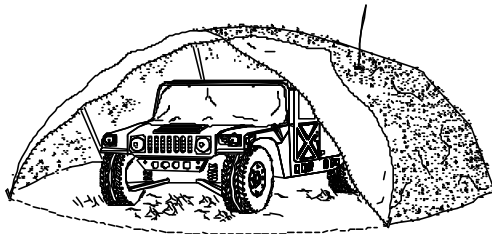

ULCANS\_2\_03\_0400

Figure 1-1. Ultralightweight Camouflage Net Systems (ULCANS)

##### 1-3. CONSOLIDATED INDEX OF ARMY PUBLICATIONS AND BLANK FORMS.

Refer to the latest issue of DA Pam 25-30 to determine whether there are new editions, changes, or additional publications pertaining to the equipment.

##### 1-4. MAINTENANCE FORMS, RECORDS, AND REPORTS.

a. Reports of Maintenance and Unsatisfactory Equipment. Department of the Army forms and procedures used for equipment maintenance will be those prescribed by DA Pam 738-750, Functional Users Manual for the Army Maintenance Management System (TAMMS).

## **TM 5-1080-250-12&P**

b. Reporting of Item and Packaging Discrepancies. Fill out and forward SF 364, Report of Discrepancies (ROD), as prescribed in AR 735-11-2/DLAR 4140.55.

c. Transportation Discrepancy Report (TDR) SF 361. Fill out and forward Transportation Discrepancy Report (TDR) SF 361 as prescribed in AR 55 -38/DLAR 4500.15.

### **1-5. REPORTING EQUIPMENT IMPROVEMENT RECOMMENDATIONS (EIR).**

If your equipment needs improvement, let us know. Send us an EIR. You, the user, are the only one who can tell us what you don't like about your equipment. Let us know why you don't like the designed performance. Put it on an SF 368 (Product Quality Deficiency Report). Mail it to: Commander, US Army, Communications-Electronics Command and Fort Monmouth, ATTN: AMSEL-LC-LEO-D-CS-CFO, Fort Monmouth, New Jersey 07703-5006. We'll send you a reply.

### **1-6. ADMINISTRATIVE STORAGE.**

Administrative storage of equipment issued to and used by Army activities will have preventive maintenance checks and services (PMCS) performed before storing. When removing the equipment from administrative storage, the PMCS checks should be performed to assure operational readiness.

### **1-7. DESTRUCTION OF ARMY MATERIEL**

Destruction of Army materiel to prevent enemy use shall be in accordance with TM 750-244-3.

## **Section II. EQUIPMENT DESCRIPTION, CHARACTERISTICS, AND EQUIPMENT DATA.**

### **1-8. EQUIPMENT DESCRIPTION.**

The ULCANS, Woodland or Desert, Type III or IV, consists of the following major components: The Modular Camouflage Screen System and the Support System.

a. Modular Camouflage Screen System. The modular camouflage screen system consists of the following items (see Figure 1-2, Detail B):

- 1) 1 Hexagon Screen
- 2) 1 Rhombic Screen
- 3) 1 Screen Carrying Case
- 4) 1 Repair Kit, (See paragraph b for detail).

b. Repair Kit. A repair kit is furnished to make field repairs of the ULCANS screens and return the system to a serviceable condition. The repair kit contained in the modular camouflage screen system consist of the following items, Figure 1-2 (Detail A):

- 1) 25 Sq Ft Screen Repair Material
- 2) 300 Tiedown Straps

c. Support System. The support system consists of the following items, Figure 1-2:

- 1) 1 Carrying Case
- 2) 1 Stake Bag
- 3) 24 Anchor Stakes
- 4) 12 4' Segmented Support Poles (Aluminum)
- 5) 6 Shape Disrupters

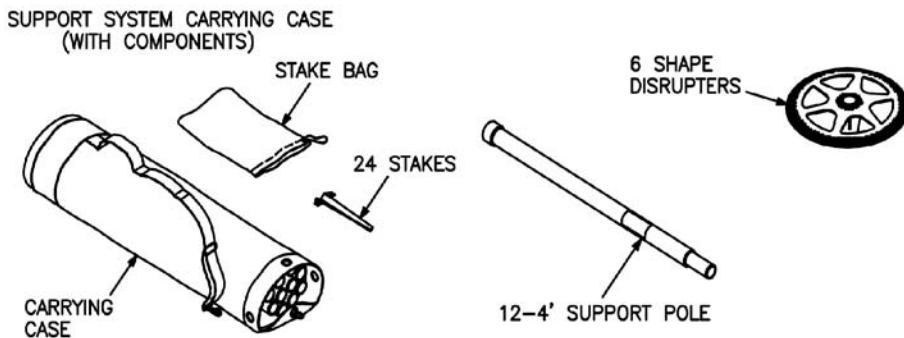
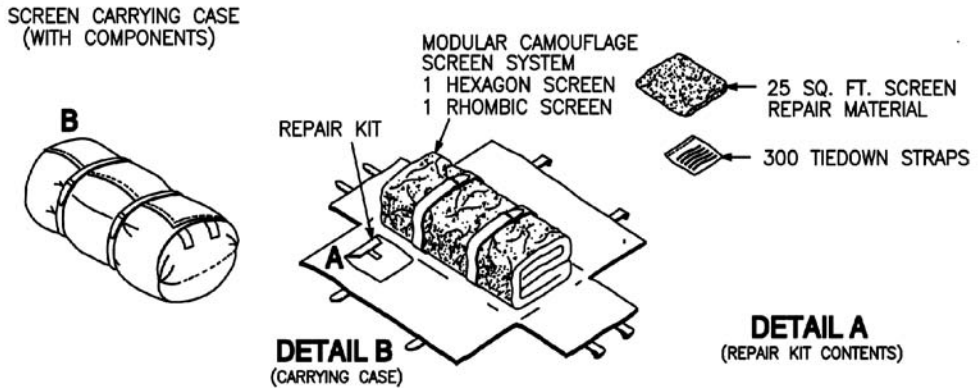

ULCANS-1-02-0899

Figure 1-2. ULCANS Components

d. Shape Disrupter Assemblies. The six shape disrupters provided with the support system provide shape disruption and an aggressive grip on the camouflage screen to prevent poles from falling if billowing of net occurs in gusty wind conditions.

### 1-9. ULCANS APPLICATIONS AND CONFIGURATION DATA.

a. The ULCANS will be used by combat troop and support units to conceal military target signatures of weapons, vehicles, and semi-permanent positions in situations where natural cover or concealment may be absent or inadequate. Any number of screens can be joined together to provide cover for a large area of concealment. For typical ULCANS applications, see Figure 1-3.

**TM 5-1080-250-12&P**

b. The ULCANS can also be used as an aid in the concealment of permanent prominent objects, and objects in a fixed pattern or array which present obvious targets. However, permanent installation camouflage will usually require construction of concealment features (false roofs, dummy buildings, garnished wire nestings, etc.). For ULCANS configuration data refer to Figure 1-4. Table 1-1 provides screen configuration dimensions.

c. To prevent the location and identification of military hardware by an enemy using visual, infrared, or radar devices, the ULCANS can be temporarily placed over halted vehicles, weapons and materials and over semi-permanent positions and installations.



SAMPLE DIMENSIONAL COVERAGE

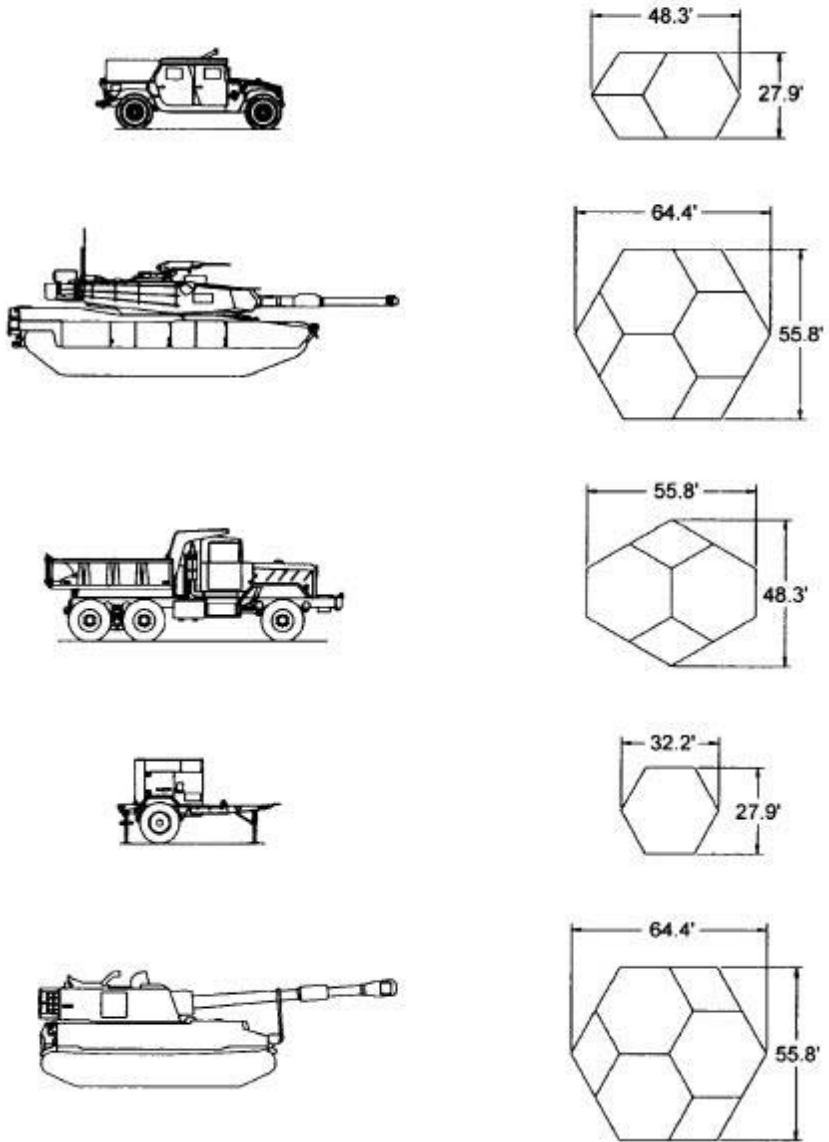

ULCANS-1-03-0399

Figure 1-3. Typical ULCANS Applications (Sheet 1 of 2)

**SAMPLE DIMENSIONAL COVERAGE**

**PEAK HEIGHT 10 FT 6 IN  
LENGTH 8 FT 9 IN  
WIDTH 17 FT 6 IN  
AREA 168.9 SQ FT**

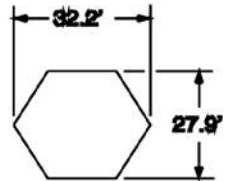
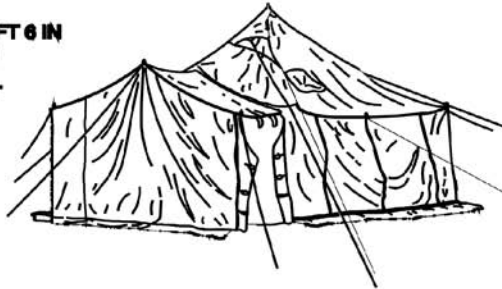

**TENT, GENERAL PURPOSE, SMALL**

**RIDGE HT 10 FT  
LENGTH 32 FT 8 IN  
WIDTH 16 FT  
AREA 612 SQ FT**

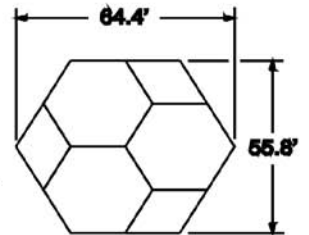
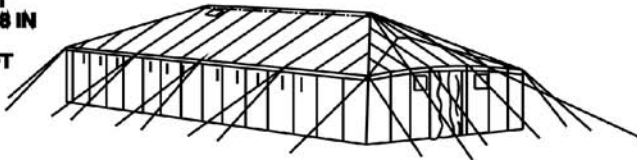

**TENT, GENERAL PURPOSE, MEDIUM**

**RIDGE HT 12 FT 9 IN  
LENGTH 52 FT  
WIDTH 18 FT  
AREA 936 SQ FT**

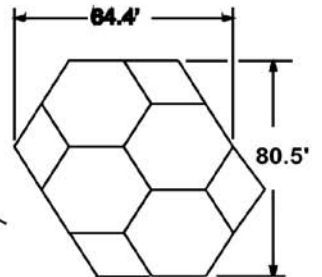
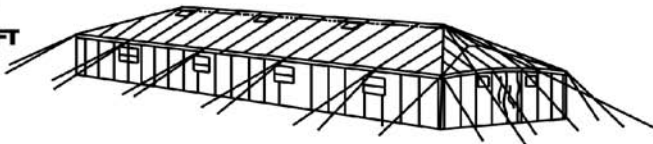

**TENT, GENERAL PURPOSE, LARGE**

Figure 1-3. Typical ULCANS Applications (Sheet 2 of 2)









<p>0 HEXAGONS 1 DIAMOND</p> <p>0A</p>  <p>LENGTH 27.9 FT. WIDTH 16.1 FT. AREA 224.5 SQ FT.</p>	<p>0 HEXAGONS 2 DIAMONDS</p> <p>0B</p>  <p>LENGTH 40.2 FT. WIDTH 13.9 FT. AREA 449.0 SQ FT.</p>	<p>3 HEXAGONS 3 DIAMONDS</p> <p>3</p>  <p>LENGTH 64.4 FT. WIDTH 55.8 FT. AREA 2694.3 SQ FT.</p>	<p>4 HEXAGONS 4 DIAMONDS</p> <p>4</p>  <p>LENGTH 80.5 FT. WIDTH 55.8 FT. AREA 3592.4 SQ FT.</p>
<p>1 HEXAGON 0 DIAMONDS</p> <p>1A</p>  <p>LENGTH 32.2 FT. WIDTH 27.9 FT. AREA 673.6 SQ FT.</p>	<p>1 HEXAGON 2 DIAMONDS</p> <p>1B</p>  <p>LENGTH 48.3 FT. WIDTH 27.9 FT. AREA 1122.6 SQ FT.</p>	<p>5 HEXAGONS 6 DIAMONDS</p> <p>5</p>  <p>LENGTH 83.7 FT. WIDTH 80.5 FT. AREA 4715.0 SQ FT.</p>	<p>6 HEXAGONS 8 DIAMONDS</p> <p>6</p>  <p>LENGTH 104.7 FT. WIDTH 69.7 FT. AREA 5837.6 SQ FT.</p>
<p>1 HEXAGON 4 DIAMONDS</p> <p>1C</p>  <p>LENGTH 64.4 FT. WIDTH 27.9 FT. AREA 1571.7 SQ FT.</p>	<p>2 HEXAGONS 2 DIAMONDS</p> <p>2</p>  <p>LENGTH 55.8 FT. WIDTH 48.3 FT. AREA 1796.2 SQ FT.</p>	<p>7 HEXAGONS 6 DIAMONDS</p> <p>7A</p>  <p>LENGTH 96.6 FT. WIDTH 83.7 FT. AREA 6062.1 SQ FT.</p>	
<p>7 HEXAGONS 11 DIAMONDS</p> <p>7B</p>  <p>LENGTH 111.6 FT. WIDTH 96.9 FT. AREA 7184.7 SQ FT.</p>	<p>8 HEXAGONS 9 DIAMONDS</p> <p>8</p>  <p>LENGTH 112.7 FT. WIDTH 83.7 FT. AREA 7409.2 SQ FT.</p>	<p>NOTE: "LENGTH" IS THE MEASUREMENT FROM LEFT TO RIGHT. NUMBER IN UPPER RIGHT DENOTES MODULE CONFIGURATION.</p>	
<p>9 HEXAGONS 12 DIAMONDS</p> <p>9</p>  <p>LENGTH 128.8 FT. WIDTH 83.7 FT. AREA 8756.4 SQ FT.</p>	<p>10 HEXAGONS 10 DIAMONDS</p> <p>10</p>  <p>LENGTH 112.7 FT. WIDTH 111.6 FT. AREA 8980.9 SQ FT.</p>		

Figure 1-4. Screen Configuration Data

Table 1-1. Screen Configuration Dimensions

* Configuration (Figure 1-4)	Length FT	Width FT	Area SQ FT
0A	27.9	16.1	224.5
0B	40.2	13.9	449.0
1A	32.2	27.9	673.6
1B	48.3	27.9	1,122.6
1C	64.4	27.9	1,571.7
2	55.8	48.3	1,796.2
3	64.4	55.8	2,694.3
4	80.5	55.8	3,592.4
5	83.7	80.5	4,715.0
6	104.7	69.7	5,837.6
7A	96.6	83.7	6,062.1
7B	111.6	96.9	7,184.7
8	112.7	83.7	7,409.2
9	128.8	83.7	8,756.4
10	112.7	111.6	8,980.9

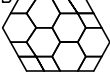
\* NOTE: Configuration number denotes screen configuration number located in upper right corner of Figure 1-4 Screen Configuration Data.

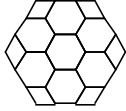
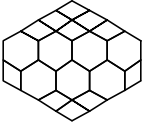
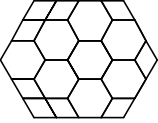
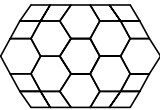
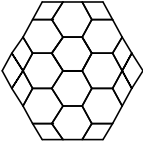
**1-10. MODULE DETERMINATION CHART**

The chart in Figure 1-5 is used to determine the number of screen modules required to cover your equipment. Table 1-1 will also aid you in making your decision.

To determine the number of screen modules, calculate "A" and "B". Find "A" value (screen width, in feet) on the Module Determination Chart and go across to "B" value (screen length, in feet). Where "A" and "B" intersect on the chart will give you the number of screen modules required.

Formulas  $A=2h + w + 5ft$  and  $B=2h + L + 5ft$  have been devised to determine the number of screen modules required. Do calculations in feet.

- h = height of object, in feet + 2 feet (for overhead clearance)
- L = length of object, in feet
- w = width of object, in feet
- A = width of screen in feet
- B = length of screen in feet

That part of the object which falls within the slope of about 50° can be disregarded in determining "L" or "w". A slope of about 50° gives maximum effectiveness in camouflage.

Example:  $A=2(8\text{ ft} + 2\text{ ft}) + 10\text{ ft} + 5\text{ ft}$ ;  $B=2(8\text{ ft} + 2\text{ ft}) + 25\text{ ft} + 5\text{ ft}$ ;  $A=35$ ,  $B=50$ . The nearest size of screen according to the chart is a two module configuration. Keep in mind that the formulas and charts are guides and the selection of screens and the combinations must be tailored to the individual situation.

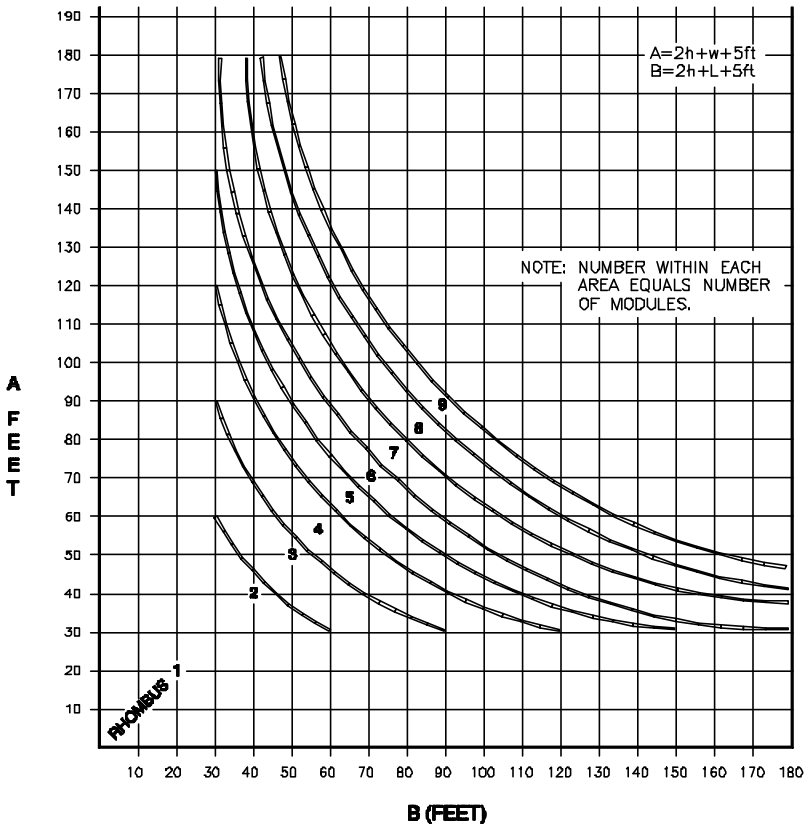

ULCANS-1-06-D389

Figure 1-5. Module Determination Chart

1-11. TABULATED DATA

**WARNING**

A minimum of a "two-man lift" is required for both the ULCANS screen system and the support system storage/transport containers. Components may increase in weight due to trapped or absorbed water.

- a. Total weight of packaged ULCANS is approximately 94.5 lbs. (Woodland) and 105 lbs (Desert).
- b. Weight and cube of packaged Woodland ULCANS camouflage screen system is: approximately 52.5 lbs; 5.0 cu ft.
  - (1) Hexagon Screen - 32 lb
  - (2) Rhombic Screen - 12 lb
  - (3) Repair Kit - 2 lb
  - (4) Carrying Case, Screen System - 6.5 lb
- c. Weight and cube of packaged Woodland ULCANS support system is approximately 42 lbs; 5.0 cu ft.
  - (1) Support Poles - 26 lb
  - (2) Stakes - 6 lb
  - (3) Shape Disrupter - 6 lb
  - (4) Carrying Case, Support System - 3 lb
- d. Weight and cube of packaged Desert ULCANS camouflage screen system is approximately 63 lbs; 5.0 cu ft.
  - (1) Hexagon Screen - 40 lb
  - (2) Rhombic Screen - 14 lb
  - (3) Repair Kit - 2.5 lb
  - (4) Carrying Case, Screen System - 6.5 lb
- e. Weight and cube of packaged Desert ULCANS support system is approximately 42 lbs; 5.0 cu ft.
  - (1) Support Poles - 26 lb
  - (2) Stakes - 6 lb
  - (3) Shape Disrupter - 6 lb
  - (4) Carrying Case, Support System - 3 lb

1-12. CLASSIFICATION, CAMOUFLAGE SCREENING TYPES AND CLASS

**CAUTION**

- Proper identification of screens must be maintained at all times. Do not remove or lose identification tags that are attached to screens. **Do not use a transparent screen in place of a radar scattering screen.** When two or more screens are joined together, ensure that the screens are of the same type by checking each screen's identification tag.
- The radar scattering ULCANS must not be placed over active radar equipment because it will seriously interfere with the operation of radar equipment underneath it.

a. Classification, Type, Class and Frequency. ULCANS provides concealment of military ground equipment when tactically deployed. ULCANS will provide visual, electro-optic, radar, and infrared signature reduction characteristics. ULCANS Type III shall be used for general purpose, radar transparent and Type IV shall be used for general purpose, radar scattering concealment.

ULCANS Type III - Used for general purpose visual (radar transparent) concealment of tactical systems.

Class 1 - Woodland  
Class 2 - Desert

ULCANS Type IV - Used for general purpose radar scattering concealment of tactical systems, 6-94 GHz radar scattering.

Class 1 - Woodland  
Class 2 - Desert

b. Table 1-2, Table 1-3, and Table 1-4 provide weight, minimum support system components, and maximum pole heights for Type III and IV screen systems.

Table 1-2. Total System Weight

Screen Type	Total System Weight, Maximum
Woodland, Type III and IV	94.5 lb
Desert, Type III and IV	105 lb

Table 1-3. Number Of Support System Components

ULCANS Support System	Stakes	Screen Supports	Shape Disrupters	Storage/Transport Container
Type III and IV	24	12	6	1

Table 1-4. Height of Support Poles

ULCANS Support System	Height of Poles	Height of Poles, Retracted
Type III and IV	48"	N/A

c. There are no visual differences between radar scattering screens and radar transparent screens. When two or more screens are joined together, ensure that the screens are of the same type by checking the screen identification tag located at two corners of each screen. See Figures 1-6 and 1-7 for examples.

d. The ULCANS Type IV Class 1 and Class 2 screens should never be used to camouflage active radar transmitters, receivers, or whip antennas. Whip antennas should protrude through camouflage screens. See deployment instructions in Chapter 2.



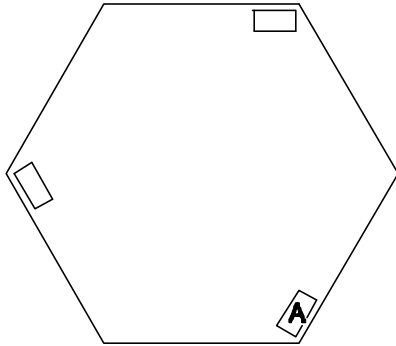

HEXAGON

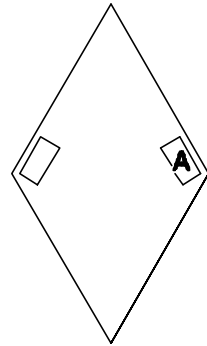

RHOMBIC

SCREEN NSN:  
CAMOUFLAGE SCREEN (HEXAGON OR RHOMBIC)  
ULCANS - CLASS 1 - WOODLAND  
TYPE (SCREEN TYPE)-RADAR SCATTERING  
CAGE: 19397/PART NO:  
(CONTRACT NUMBER)  
(LOT NUMBER)

**VIEW A**

ULCANS-1-05-0200

Figure 1-6. Position of Screen Identification Tags

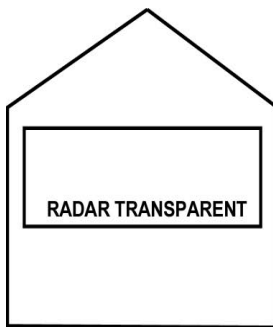

**Identification Tag for Screen,  
Radar Transparent**

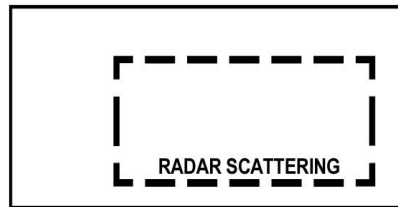

**Identification Tag for Screen,  
Radar Scattering**

Figure 1-7. Radar Transparent and Radar Scattering Screen Identification Tags

## CHAPTER 2

## OPERATING INSTRUCTIONS

## Section I. OPERATION UNDER NORMAL CONDITIONS

## 2-1. GENERAL.

When deploying the ULCANS over vehicles, weapons, and semi-permanent positions, care must be exercised to prevent the garnished (top) side of the screen from tearing on sharp corners, extruding pointed objects, or accessories such as mirrors, bumpers, antennas, mounted armament, poles, stakes, beams, etc. If multiple screens are required, screens will be assembled prior to deployment. When deploying ULCANS, a screen location should be identified at the outside edge for an entry/egress doorway for personnel, equipment, or vehicles as required. Inventory ULCANS contents and assemble multiple screen systems as required before placing over the item to be camouflaged.

## Section II. ULCANS DEPLOYMENT/RETRIEVAL INSTRUCTIONS

## 2-2. DEPLOYMENT INSTRUCTIONS.

The following instructions shall apply when deploying ULCANS.

**WARNING**

- The radar scattering ULCANS must not be placed over active radar equipment because it will seriously interfere with the operation of radar equipment underneath it.
- To prevent personal injury, a minimum of a "two-person lift" is required for both the ULCANS screen system and the support system storage/transport containers. Components may increase in weight due to trapped or absorbed water. Use additional personnel as needed
- To prevent personal injury, secure dog tags, remove jewelry, individual equipment, and clothing items that can become snagged during deployment or striking of ULCANS screens. Failure to observe this warning can result in severe injury, loss of limb or death from falling.
- Climbing on and around the equipment to deploy ULCANS can pose a fall hazard. Extreme caution should be observed to avoid slippery or uneven surfaces and other trip hazards. Use handhold when provided and ladders when available.
- Particles of dirt and debris carried by netting/garnish can be scraped off and fall into the operator's eyes when looking upward during setup and takedown of ULCANS. Eye protection is required during setup and takedown operations of ULCANS.

**CAUTION**

Proper identification of screens must be maintained at all times. Do not remove or lose identification tags that are attached to screens. Do not use a transparent screen in place of a radar scattering screen. When two or more screens are joined together, ensure that the screens are of the same type by checking each screens' identification tag.

Keep screens away from all hot exhaust systems, (Includes vehicles, heaters, stoves, etc.). Screens can be damaged if not struck and removed from back blast of field artillery prior to firing.

a. ULCANS Deployment. Prior to deploying the ULCANS system personnel should remove jewelry, individual equipment, and loose clothing items and secure dog tags that may become snagged during deployment of screens. Wearing of eye protection and hand protection is recommended during setup and takedown. During the movement, positioning, and deployment of the ULCANS screen system and support systems, a two person lift minimum is required. A four person team is recommended for multiple screen deployments. Climbing on and around equipment during the deployment of equipment poses a fall hazard and extreme caution shall be exercised. Caution shall be observed to avoid uneven, slippery surfaces and other trip hazards that may be present. Use handholds when present and ladders when available. Ladders should be used only on level firm terrain and steadied by a second person. Do not stand on top step of ladder. During deployment keep screens away from all hot exhaust systems, vehicles, stoves, heaters etc. Screens can be damaged if not struck and removed from back blast area of field artillery prior to firing. To prevent snagging of screens, stow or remove equipment or accessory items protruding from the side of vehicles, fold in external vehicle mirrors, and lower or secure antennas. These steps will also prevent collision with support poles during vehicle movement.

**WARNING**

Personnel are subject to being burned by hot components and exhausts if deployment of the ULCANS is attempted with the equipment's engine running or immediately after the engine is turned off. A cool down period shall be observed prior to ULCANS deployment except in emergency conditions; then wear hand protection and exercise extreme caution when working in area of hot components.

b. Cool Down Period. A cool down period of equipment engines shall be observed immediately after being turned off prior to ULCANS deployment except in emergency conditions. Refer to the specific engine technical manual for information on the appropriate cool-down period. Hand protection shall be worn and extreme caution exercised when working in the area of hot components or engines.

c. Multiple Screen Assembly. When joining multiple screens, first spread the screens to be joined over a level ground site free from large rocks, sharp objects and debris. ULCANS is designed so that when joining multiple screens, pattern continuity is always maintained. Screen positioning for pattern matching is not necessary. Assemble and secure multiple screens by looping Beackets together. Begin looping Beackets at the highest point, work to the lowest point, and end at the closest point to the outside edge as possible. Secure by tying a knot in the last Beacket in series. Avoid having knots high off the ground or in the center of a screen which can make the quick separation of multiple screens difficult. For detailed multiple screen assembly refer to Figure 2-1. Roll or fold multiple screens as necessary (Figure 2-2) before placing over the item to be camouflaged.

d. Shape Disruption. For effective concealment of vehicles, weapons, or other semi-permanent objects, a minimum space of two feet between the screen and the top of the objects of concealment is recommended unless the object is used as part of the shape disruption. **Under no circumstances should screens be draped over a vehicle or other object of concealment without using shape disrupters.** Draping the screen will show the outline and thermal signature of the vehicle, weapon, or concealed object underneath and will allow immediate recognition by enemy forces, thus defeating the purpose of camouflage. **The support poles and shape disrupters must be used at all times.** The shape of the screen should be disrupted as much as possible by placing support assemblies underneath the screens at various positions and heights. When possible, avoid vertical sides when positioning shape disrupters. Slope sides outward as much as possible, pulling edges to the ground all the way around the net system. String, twine, or light rope may be used to connect screen to a stake that must be repositioned in rocky soil. Poles should be installed firmly to maintain support in windy/blustery conditions. For detailed ULCANS deployment see Figure 2-2.

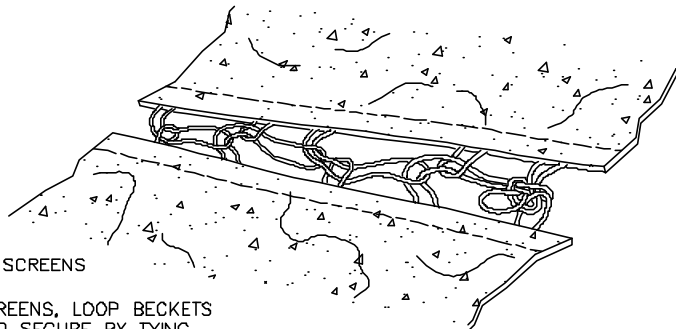

**A** JOINING MULTIPLE SCREENS

TO JOIN MULTIPLE SCREENS, LOOP BECKETS TIGHTLY TOGETHER AND SECURE BY TYING OFF THE LAST BECKET IN LINE.

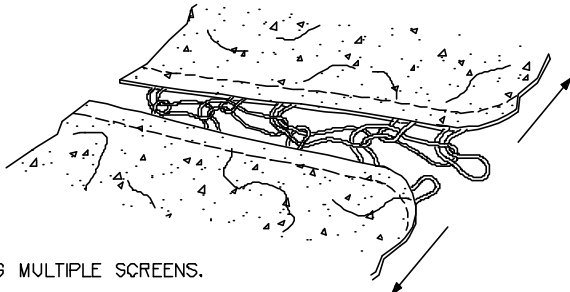

**B** DISCONNECTING MULTIPLE SCREENS.

UNTYING THE KNOTTED BECKET AND PULLING THE SCREENS IN THE OPPOSITE DIRECTION CAUSES A QUICK RELEASE OF SCREEN BECKETS TO BE ACCOMPLISHED.

NOTE: WHEN USING MULTIPLE SCREEN TECHNIQUE, CONNECT ALL SCREENS TO BE USED BEFORE ERECTING.

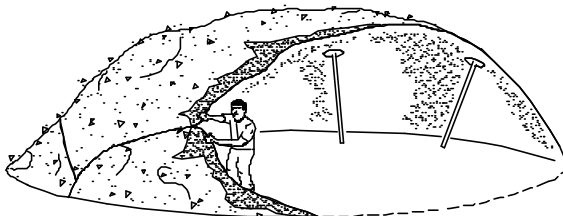

**C** MULTIPLE SCREEN RETRIEVAL.

EMERGENCY RETRIEVAL: MULTIPLE SCREENS MAY BE SEPARATED WHILE ULCANS IS DEPLOYED. LEAN SUPPORT POLES AWAY FROM EMBRASURE TO ALLOW FOR SCREEN SEPARATION. THIS PROCEDURE WILL ALLOW REMAINING SCREENS TO COLLAPSE.

NORMAL RETRIEVAL: CAMOUFLAGED ITEM(S) SHALL BE REMOVED FROM AREA, SUPPORT POLES REMOVED AND SCREEN SYSTEM LOWERED BEFORE SEPARATING MULTIPLE SCREENS.

ULCANS-2-01-1098

Figure 2-1. Multiple Screen Assembly and Disassembly Instructions

**INSTRUCTIONS FOR ERECTING ULTRALIGHTWEIGHT CAMOUFLAGE SCREENING**

**NOTE**

Follow steps below for assembling procedure.

**STEP 1 INVENTORY ULCANS CONTENTS**

SCREEN CARRYING CASE  
(WITH COMPONENTS)

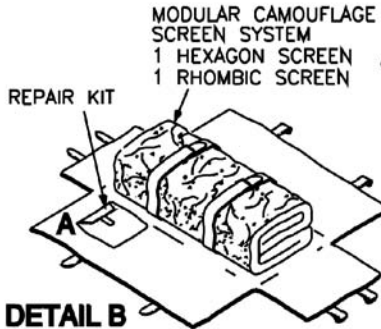
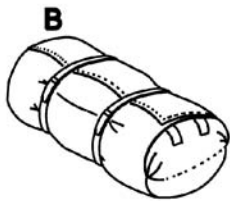

- 25 SQ. FT. SCREEN REPAIR MATERIAL
- TM 5-1080-250-12&P
- 300 STRAPS, TIEDOWN

**DETAIL B**  
(CARRYING CASE)

**DETAIL A**  
(REPAIR KIT CONTENTS)

SUPPORT SYSTEM CARRYING CASE  
(WITH COMPONENTS)

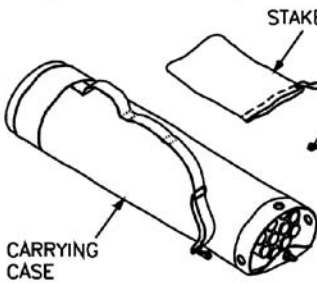

STAKE BAG

24 STAKES

6 SHAPE DISRUPTERS

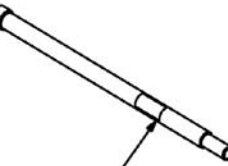

12-4' SUPPORT POLE

ULCANS2-02A-0899

Figure 2-2. Deployment/Retrieval/Storage Instructions, ULCANS (Sheet 1 of 9)

STEP 2A

PROCEDURE FOR UNFOLDING/FOLDING SINGLE SCREEN FOR DEPLOYMENT/RETRIEVAL/STORAGE

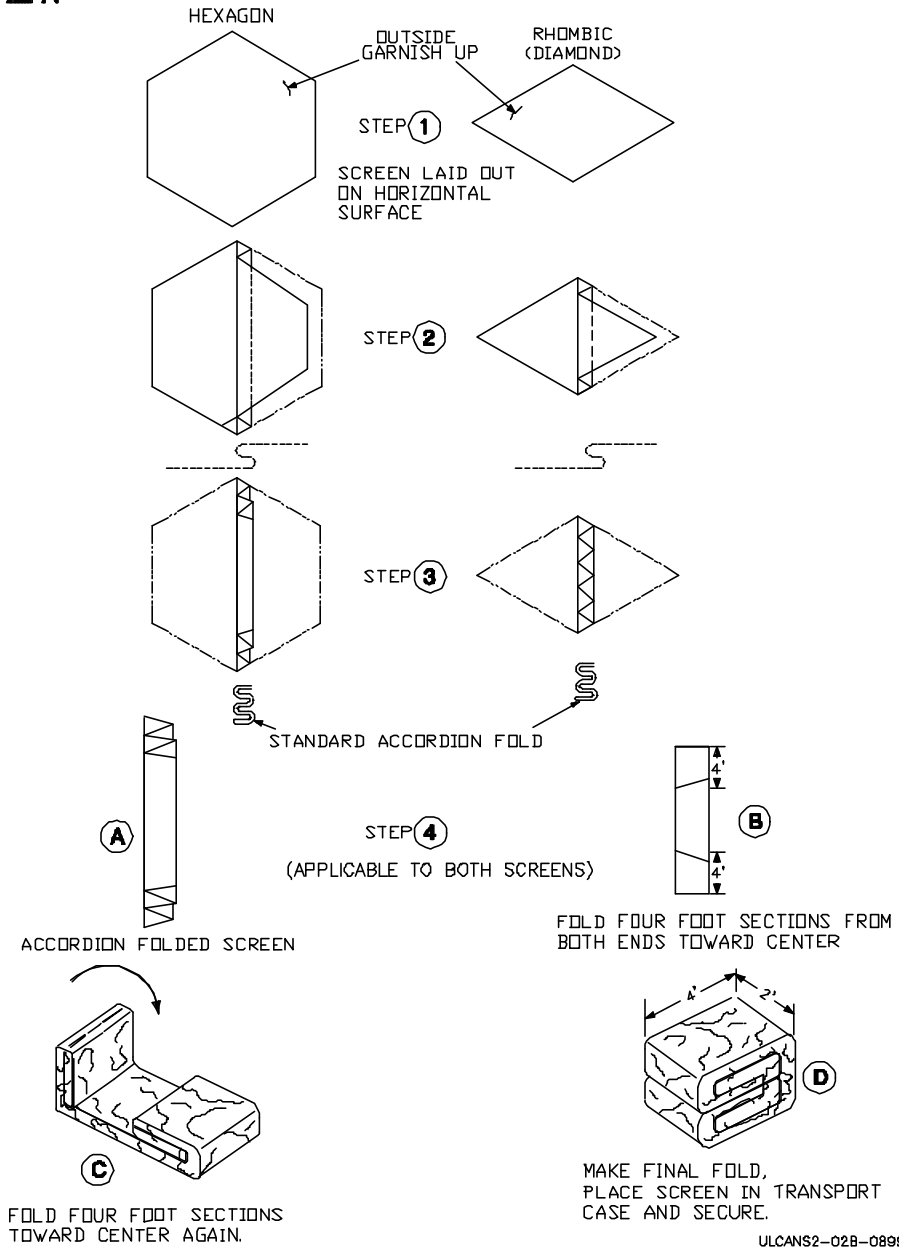
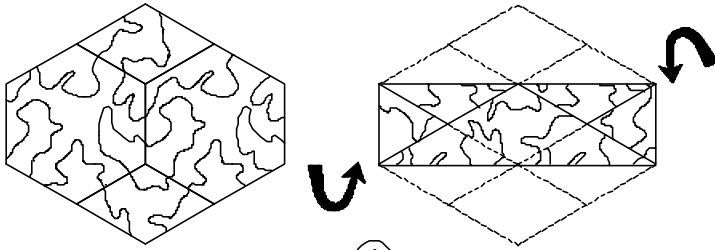

Figure 2-2. Deployment/Retrieval/Storage Instructions, (Sheet 2 of 9)



STEP 2B

METHOD FOR UNFOLDING/FOLDING MULTIPLE SCREENS  
FOR DEPLOYMENT/RETRIEVAL/STORAGE



STEP 1  
LAY SCREENS OUT

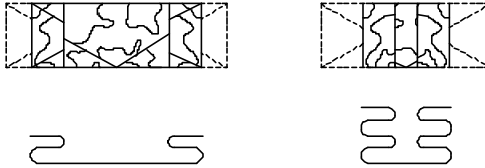

STEP 2  
STANDARD ACCORDION FOLD

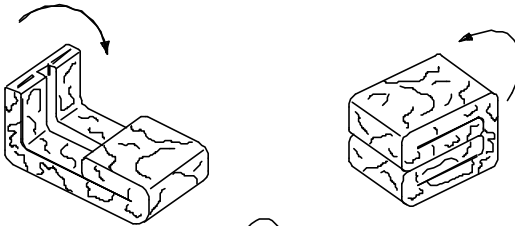

STEP 3

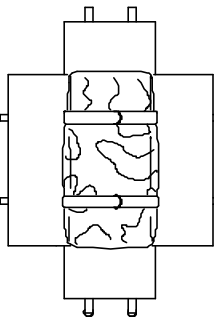

STEP 4

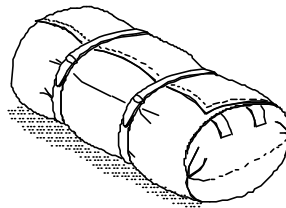

NOTE: ABOVE PROCEDURE FOR FOLDING  
MULTIPLE SECTIONS.

ULCANS2-2C-0899

Figure 2-2. Deployment/Retrieval/Storage Instructions, ULCANS (Sheet 3 of 9)

STEP 2c

PROCEDURE FOR UNROLLING/ROLLING MULTIPLE SCREENS FOR DEPLOYMENT/RETRIEVAL/STORAGE

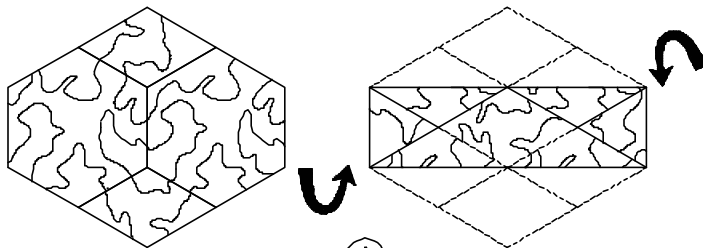

STEP 1  
LAY SCREENS OUT



STEP 2



STEP 3

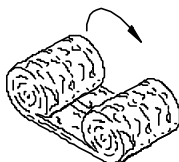

STEP 4

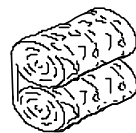

ULCANS2-02D-0899

Figure 2-2. Deployment/Retrieval/Storage Instructions, ULCANS (Sheet 4 of 9)

ERECTING PROCEDURE FOR MULTIPLE SCREEN SYSTEM.

NOTE: POSITION SCREEN ON THE TOP OF THE ITEM BEING CAMOUFLAGED.  
UNFOLD SCREEN BY THE SIDES OF THE SCREENS.

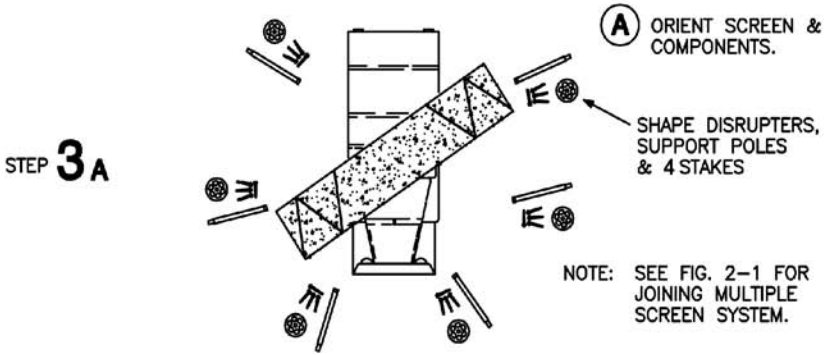

NOTE: POSITION SCREEN ON THE TOP OF THE ITEM BEING CAMOUFLAGED.  
UNROLL SCREEN FROM END TO END THEN UNROLL SIDES.

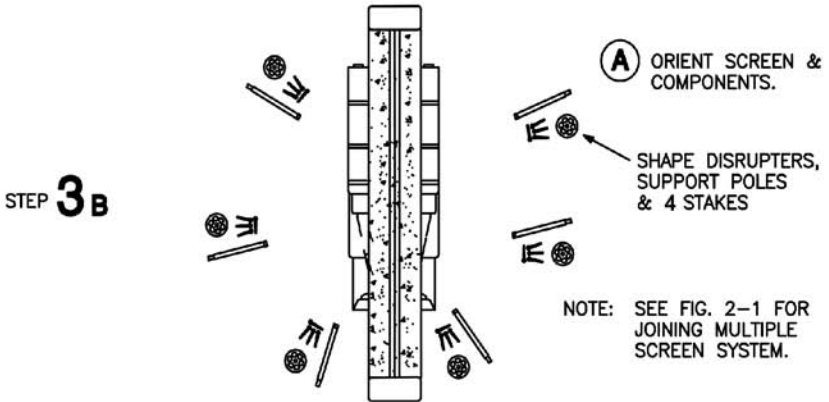

ULCANS2-02E-0899

Figure 2-2. Deployment/Retrieval/Storage Instructions, ULCANS (Sheet 5 of 9)

STEP **3** **B** CONT'D

**B** SPREAD OUT SCREEN & STAKE AT CORNER STAKE LOOPS. COMPLETE STRETCHING SCREEN AND SECURE WITH ADDITIONAL STAKE USING BECKET LOOPS AS NECESSARY.

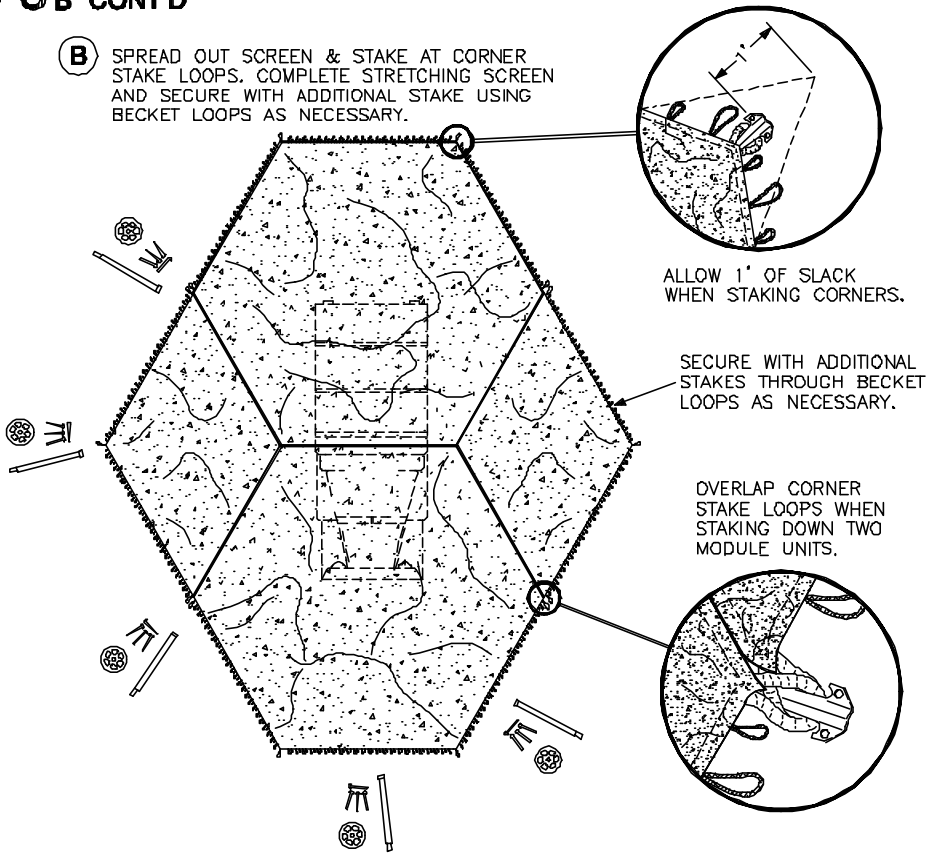

NOTE. TO PROVIDE EGRESS REMOVE FRONT STAKES, REPOSITION DISRUPTER TO ALLOW VEHICLE REMOVAL. FOLD FRONT BACK AS NECESSARY FOR REMOVAL THEN RESECURE BECKETS AND STAKE AS NECESSARY.

ULCANS2-02F-0899

Figure 2-2. Deployment/Retrieval/Storage Instructions, ULCANS (Sheet 6 of 9)

**WARNING**

DO NOT STACK SUPPORT POLES MORE THAN FOUR SECTIONS HIGH.

**(A)** POLE SYSTEM

STEP **4**

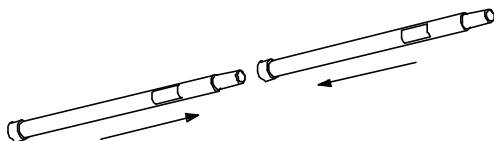

**(B)** TO EXTEND SUPPORT POLES TO DESIRED LENGTH REMOVE SECTIONS FROM CARRYING CASE AND INSERT SMALL END OF ONE POLE INTO LARGE END OF OTHER POLE.

PLACE SHAPE DISRUPTER OVER TOP OF POLE UNTIL DISRUPTER IS FIRMLY SEATED.

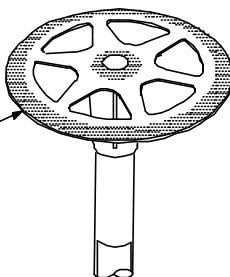

MORE THAN 1 SUPPORT POLE CAN BE USED FOR EXTENDED POLE LENGTH.

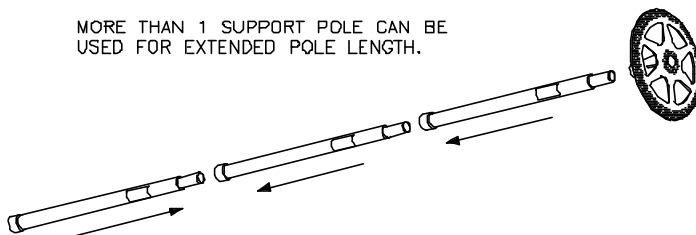

ULCANS2-02G-0899

Figure 2-2. Deployment/Retrieval/Storage Instructions, ULCANS (Sheet 7 of 9)

**STEP 5** POSITION VEHICLE SO THAT ANTENNA EXTENDS THROUGH BECKET SEAM

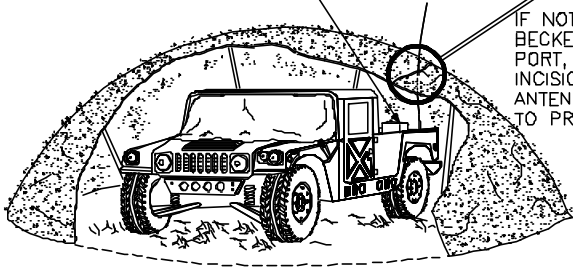

IF NOT PRACTICAL TO USE BECKET SEAM AS AN ANTENNA PORT, CUT A SMALL X-SHAPED INCISION IN SCREEN OVER ANTENNA AND ALLOW ANTENNA TO PROTRUDE THROUGH CUT

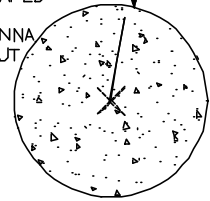

ULCANS2-02H-0899

**STEP 6**

**NOTE: RECOMMEND A MINIMUM OF 2 FEET OF SPACE BE MAINTAINED BETWEEN SCREENS AND VEHICLE.**

PLACE SUPPORT POLE AS CLOSE TO VEHICLE AS POSSIBLE. STAGGER SUPPORT POLES TO DISRUPT STRAIGHT LINES.

CANVAS FLAP LOWERED TO HIDE THE SHADOW.

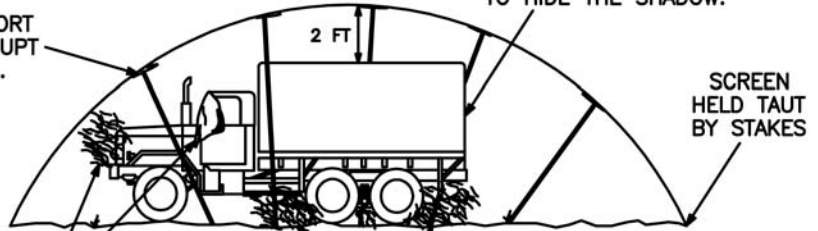

LIGHTS COVERED WITH BRUSH, WINDSHIELD WITH TARPAULIN.

BREAK UP RECOGNIZABLE SHADOWS WITH BRUSH.

SCREEN HELD TAUT BY STAKES

ULCANS2-02J-0899

Figure 2-2. Deployment/Retrieval/Storage Instructions, ULCANS (Sheet 8 of 9)

PLACEMENT OF SHAPE DISRUPTERS

STEP 6 CONT'D

PERSON NO. 1

WITH SHAPE DISRUPTER FIRMLY SEATED ON SUPPORT POLE PUSH SHAPE DISRUPTER UP, ATTACHING ADDITIONAL SUPPORT POLES AS REQUIRED TO CREATE A NON-UNIFORM SHAPE.

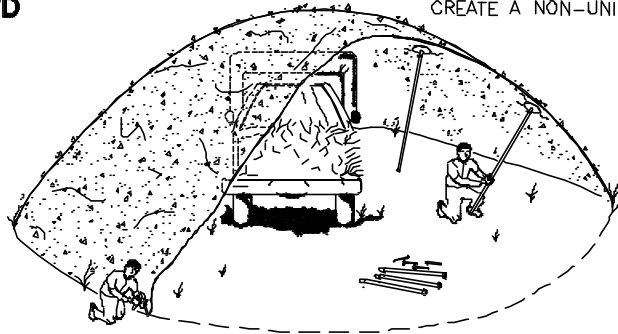

PERSON NO. 2

REPOSITION CORNER STAKES AS NECESSARY TO TIGHTEN SCREEN  
STAKE BETWEEN CORNERS TO TIGHTEN SCREEN, BEING CAREFUL TO STAKE ONLY THE EDGE CORD.

ULCANS2-02K-0899

Figure 2-2. Deployment/Retrieval/Storage Instructions, ULCANS (Sheet 9 of 9)

**WARNING**

Support poles will conduct electricity. To prevent electrical shock, do not allow support poles to contact sources of electricity during deployment or retrieval

**CAUTION**

In desert environments, the support poles and metal stakes left in direct sunlight can become extremely hot to touch. Wear gloves to prevent burns.

e. Support Poles. For ease of assembly and disassembly of the support pole sections, keep both ends of the support poles free from dirt, mud and foreign matter. Wipe both ends clean before assembly. Care should be taken to prevent damage to the support pole ends, which could cause an improper fit. Do not use support poles as pry bars. Inspect the support pole ends for burrs or damage before assembly (see Figure 2-2). If poles have been exposed to direct sunlight for a prolonged period, they may be very hot to touch. Wearing gloves is recommended.

f. Positioning Support Poles. When conditions require erecting the ULCANS in muddy areas, provide support poles with a firm footing by placing the poles on top of any appropriate material available, such as a flat rock, boards, brush, etc. When such material is not available, it may become necessary to add another four-foot support pole section in order to reach firm footing. Reposition support poles and shape disrupters as required.

**CAUTION**

ULCANS stakes may present a trip hazard. Drive stakes deeply to minimize area protruding above ground. Select an area without stakes for entry/egress through the screen.

g. Stakes. During deployment stakes should be driven to a depth so as to minimize protrusions to prevent tripping and fall hazards. When moving, repositioning, or performing a takedown of the ULCANS, ensure the removal of all stakes. To remove stakes, use a hammer to tap stake side to side until ground becomes loose enough to remove stake by hand. Also, stakes can be removed by grasping both ends of a spare stake, placing the middle of the spare stake under the head of the stake being removed, and pulling up.

h. Special Assembly Instructions. The following special instructions apply when ULCANS is being erected over the whip-type antennas used on SINCGARS radio sets or similar radios.

- (1) Position equipment and antenna locations so as to use the Becket seams as antenna ports. This allows antennas to fit between the seams of adjoining screens. Ensure that screen Becketts are retied and no gaps exist between adjoining screens and the antenna port. This method will eliminate unnecessary screen cuts and repair time.
- (2) If using the Becket seam as an antenna port is not practical, use a knife to cut a small X-shaped incision in the screen above the whip antenna and allow the antenna to protrude through the cut.
- (3) Place all aluminum support poles a minimum distance of four feet from the antenna.
- (4) When the screen is taken down or the antenna is removed, repair the screen using appropriate materials from the repair kit. For detailed instruction refer to Chapter 3, Maintenance Instructions.

**WARNING**

- Volatile fuels create a fire hazard and can cause explosions. This hazard is always present but most prevalent during hot weather. When volatile fuels are stored under ULCANS, steps will be taken to ensure adequate ventilation of the camouflaged area.
- Combustion by-products of ULCANS can be toxic. Evacuate the area and stay out of the path of smoke in cases where ULCANS systems are exposed to fire. Self-contained breathing apparatus is required when fighting an ULCANS fire.



i. Volatile Fuels and Hazardous Materials. Volatile fuels and hazardous or combustible materials create a fire and explosion hazard. These hazards are always present but are most prevalent during hot weather conditions. When storing hazardous or combustible materials or volatile fuels under ULCANS, steps will be taken to ensure adequate ventilation of the camouflaged area. In the event of fire, combustion by-products of the ULCANS can be toxic. Self-contained breathing apparatus is required when fighting an ULCANS fire.

<b>CAUTION</b>
----------------

- When using an ULCANS multi-screen configuration (of 8 ft high or more), camouflage screens can be blown down when winds exceed 46 miles per hour. Damage to equipment may result. When winds in excess of 46 miles per hour are expected, screens shall be lowered and secured.
- When heavy snow, sleet, or freezing rain is expected or occurring, screens shall be lowered and secured.

j. Deployment Checks. After screens are erected, they should be checked on a daily basis for proper deployment and tightened as required. The screens should be checked more frequently during strong winds, heavy snowfalls, sleet or freezing rain. Do not allow any great accumulation of snow or ice to form on screens. Snow or ice must be removed from the screens as soon as screens start to sag and begin to show signs of stress or strain due to the excessive weight.

k. ULCANS Entry/Egress Doorway. An entry/egress doorway for the ULCANS can be created as required using a Becket seam. For personnel to enter or leave the deployed ULCANS, tie off a Becket seam approximately four feet from the ground and position stakes so that the Becket seam will remain closed. Personnel may loosen a stake strap and fold the seam back to enter or exit. Make sure to replace the material and stake strap after use. If a Becket seam is placed in front of a concealed vehicle, the vehicle can exit quickly using the following steps:

- (1) Untie the Becket seam enough to let the vehicle pass through (See Figure 2-3).
- (2) Fold back the camouflage screen to avoid snagging on the vehicle.
- (3) Reposition the poles and shape disrupters as necessary to create a doorway. For large vehicles, place two poles of three pole segments each with shape disrupters (dependent upon camouflaged items/vehicle) at or near doorway entrance/exit. If necessary, personnel may raise and hold the poles to provide the necessary clearance for the vehicle to enter or exit.

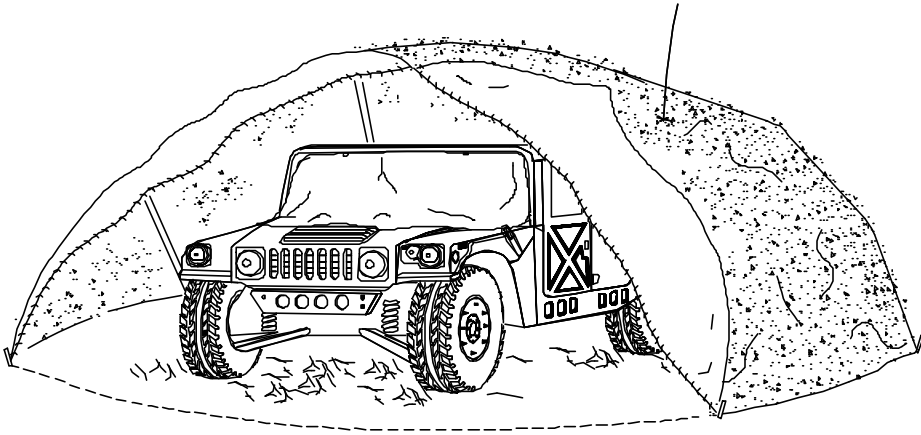

ULCANS-2-03-0499

Figure 2-3. Doorway Entrance/Egress

**2-3. RETRIEVAL INSTRUCTIONS, MULTIPLE SCREEN CONFIGURATION.**

a. Normal retrieval. Retrieval of ULCANS under normal conditions consists of dismantling the screens and folding or rolling the screen modules (see Figure 2-2).

- (1) Camouflaged item(s) shall be removed from under the ULCANS area, support poles and shape disrupters removed, and screen system lowered. Remove all ground stakes.
- (2) Spread ULCANS over level ground site free of large rocks, sharp objects and debris. Separate multiple screens as required. Repair screen as necessary, if time permits. Remove leaves, twigs, dirt or other foreign matter prior to folding and stowing in carrying cases. Wipe mud/dirt from support poles and anchor stakes before stowing. Inventory system prior to stowing for storage/transport.

b. Folding Instructions, ULCANS. Perform the following procedures for folding the ULCANS for transporting and/or storage. Refer to applicable steps in Figure 2-2.

- (1) Hexagonal Screen System. Spread the hexagonal screen on a flat surface.
  - (a) At the center of the hexagonal screen, pick up a length (approximately 2 feet) of screen from either side and make an S-shaped fold to the center of the screen.
  - (b) Pick up an equal length of screen from the opposite side and make an S-shaped fold on top of the first fold.
  - (c) Continue to make S-shaped accordion folds of equal size in the same manner until the hexagonal screen is completely folded.

- d) Each end is then folded alternately in 4 to 5 foot lengths towards the center to create a rectangle approximately 2 feet wide and four feet long. Secure folded screen in storage bag.
- (2) Rhombic Screen System. Spread the rhombic (diamond shaped) screen out on flat ground.
- (a) At the center of the rhombic screen, pick up a length (approximately 2 feet) of screen from either side and make an S-shaped fold to the center of the screen.
  - (b) Pick up an equal length of screen from the opposite side and make an S-shaped fold on top of the first fold.
  - (c) Continue to make S-shaped accordion folds of equal size in the same manner until the rhombic screen is completely folded.
  - (d) Each end is then folded alternately in 4 to 5 foot lengths towards the center to create a rectangle approximately 2 feet wide and four feet long. Secure folded screen in storage bag.

c. Roll Method for Multiple Screens. If necessary, leave multiple screens assembled during redeployment or movements to save time. For transporting or storage of assembled multiple screens, a roll method is recommended due to the bulk and weight. To save redeployment time, the rolled screens should stay with the same object they concealed previously. Recommended rolling and unrolling methods are described below. Refer to Figure 2-2.

- (1) Spread assembled multiple screens on flat ground, garnish side up. Fold two longest outside edges to meet in the center of the screen area. Roll the folded outside edges to meet in the center. Select one end of rolled screen and roll toward the center, then roll the other end in the same manner. Use available rope or strong twine to secure roll as necessary.
- (2) To redeploy screens, place the rolled-up screens in the center of the object to be covered. Orient screens so that the longest outside edges, which unroll first, will cover the proper areas. Unroll screen outward in both directions from the center, then unroll and unfold from the sides. Make sure that Becket seams used for ingress/egress are placed properly. When position of screens is correct, proceed with installation of poles and stakes.

d. Special Tools. There are no special tool requirements for deploying, retrieving, or maintaining the ULCANS. A hammer for driving stakes is required. A trenching tool or shovel for leveling or clearing the area is recommended. Appendix E lists a hammer and additional authorized items.

**Section III. OPERATION UNDER UNUSUAL CONDITIONS**

**2-4. OPERATING UNDER UNUSUAL CONDITIONS.**

Operation under unusual conditions includes deployment in inclement weather and retrieval in emergency conditions. When operating in unusual conditions it may be necessary to use longer stakes to accommodate soil or other varying conditions. Additional stake NSNs can be found in Appendix E, Additional Authorization List.

**WARNING**

- When using an ULCANS multi-screen configuration (of 8 ft high or more), camouflage screens can be blown down when winds exceed 46 miles per hour. Damage to equipment may result. When winds in excess of 46 miles per hour are expected, screens shall be lowered and secured.
- When heavy freezing rain, sleet or snow is expected or occurring, screens shall be lowered and secured.

**CAUTION**

In desert environments, the support poles and metal stakes left in direct sunlight can become extremely hot to touch. Wear gloves to prevent burns.

- a. Inclement Weather.
  - (1) When high winds in excess of 46 miles per hour are occurring or are expected, the ULCANS should be lowered and secured. During gusty windy conditions frequent checks should be made to ensure that stakes and tiedown points remain secure to prevent billowing and sagging.
  - (2) When heavy freezing rain, sleet or snow is expected or occurring, screens shall be lowered and secured. During inclement weather conditions such as snow, rain, and sleet, more frequent checks should be made for signs of stress or strain.
- b. Emergency Retrieval:
  - (1) Remove camouflaged item(s)/vehicle from underneath ULCANS prior to retrieval when possible. If removal is not possible and separation of multiple screens is not required, then support poles and shape disrupters should be removed from underneath and away from camouflaged item(s)/vehicle to prevent damage or injury to personnel during retrieval. Remove all ground stakes. On large vehicles such as trucks, tanks, Patriot Missile system, or Stinger Man-Pads, etc. it may be easier to keep ULCANS pre-attached, rolled, and secured to the top or side of vehicle.

- (2) When required, the multiple screen assemblies may be separated while the ULCANS is deployed. Remove camouflaged item(s)/vehicle from underneath ULCANS prior to retrieval when possible. If removal is not possible, then support poles and shape disrupters should be removed from underneath and away from vicinity of the camouflaged item(s)/vehicle to prevent damage. Leaning support poles away from the multiple assembly point will allow for screen separation to occur when Becket knot is untied, releasing Becketts. Pressure of screen weight and angle of support poles will provide Becket separation. This procedure will allow remaining screens to collapse. Personnel should use caution and remain away from area of falling support poles and shape disrupters. Remove all ground stakes.

**CHAPTER 3****MAINTENANCE INSTRUCTIONS****SECTION I. MAINTENANCE REQUIREMENTS****3-1. REPAIR REQUIREMENTS.**

- a. All maintenance functions can be performed at operator/crew or unit level.
- b. Generally, no repairs will be required on the ULCANS support system. Broken shape disrupters, bent, broken, or unusable support poles, and unusable stake anchors should be replaced as soon as circumstances permit.
- c. When accomplishing repairs the following items should be available (see Appendix E, Additional Authorization List (AAL)).
  1. File
  2. Gloves
  3. Hammer
  4. Rope/Twine
  5. Knife
- d. File off any nicks and burrs from the end of aluminum support poles to insure a proper fit. Do not use the support poles as pry bars or for any other purposes except to support ULCANS.
- e. Check the condition of the paint on the aluminum poles and spot paint any scratches or chipped places immediately. Any bright spot on the aluminum support poles will detract from the camouflage effectiveness of the system. If the aluminum support poles require painting, first clean them with soap and warm water or an approved solvent, and dry thoroughly. Use Paint, Enamel, Lusterless, Camouflage, Forest Green, or its equivalent.
- f. Repair of damaged ULCANS screens will be accomplished as necessary. Repairs of screens will consist of replacing sections of ragged, tattered or torn screen material with material contained in repair kit. Temporary repairs replacing broken/missing Becket loops and stake loops can be accomplished using available rope, twine, or tiedown straps.
- g. The repair kit is repaired by resupply of its contents.

**SECTION II. MAINTENANCE PROCEDURES****3-2. SCREEN MAINTENANCE PROCEDURES.**

- a. All maintenance functions can be performed at the operator/crew or unit level.
- b. No special tools are required for maintaining or repairing ULCANS.
- c. Maintenance consists of cleaning and repairing tears in screens.
  - (1) Cleaning Screen Systems:
    - (a) Fill two containers which will hold a camouflage screen (such as 55-gallon drums) with water, preferably warm if available.
    - (b) If using warm water, add sufficient mild detergent to one of the containers to form a soapy mixture. If cold water is used a liquid detergent is recommended.

- (c) Place the camouflage screen into the soapy water. Agitate the screen to remove dirt and any foreign matter.
- (d) When the screen is clean, remove it from the soapy water and place into container with clean rinse water and agitate. After rinsing hang screen to dry. Ensure screen is dry before re-packaging to prevent mildew.

**CAUTION**

- Only use ULCANS fabric of the same type and class as the ULCANS screen that is being repaired.
  - Proper identification of screens must be maintained at all times. Do not remove or lose identification tags that are attached to screen. Do not use a transparent screen in place of a radar scattering screen. When two or more screens are joined together, ensure that the screens are of the same type by checking each screen's identification tag.
  - When using lengths of rope to make a repair, ensure cut ends are heat sealed prior to use.
- (2) To repair screens:
- (a) There are no separate repair requirements for ULCANS garnish or netting material. These are not considered separate parts of the screen material.
  - (b) To repair a section of damaged screen material, select a piece of camouflage screen material from the screen repair kit that blends in well with the surrounding area being replaced and is of the correct type and class.
  - (c) Trim away ragged or tattered material from damaged area.
  - (d) Position repair material and attach to existing screen using tiedown straps from the repair kit as required. It is recommended that the edges of the area of the screen to be repaired be overlapped slightly when making the repair. If tiedown straps are not available then secure screen repair materials using twine, cord, string or lightweight rope, see Appendix F.
  - (e) When replacing a piece of screen material or repairing a tear, ensure mated material is tightly secured to prevent loose material or gaps at adjoining seams.

d. A missing or broken Becket loop may be bypassed when multiple screens are being assembled by looping through the next available Becket loop. However, it is recommended that when more than one Becket in a row is missing or broken, a Becket should be replaced using any available piece of tie material such as tiedown straps, twine, cord, string, etc. Refer to Figure 3-1 for detailed instructions for repair of camouflage screens.

**A** SCREEN REPAIR USING PLASTIC TIEDOWN STRAPS.

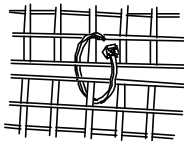

1. INSERT TIEDOWN STRAP

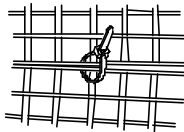

2. CINCH

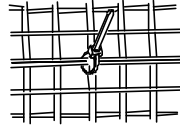

3. PULL TIGHTLY

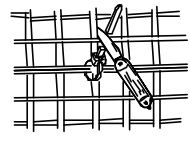

4. CUT OFF TIP

**B** IN THE EVENT ALL TIEDOWN STRAPS HAVE BEEN USED AND THERE IS ADEQUATE TIME THE FOLLOWING METHOD OF REPAIRING WITH TWINE MAY BE USED.

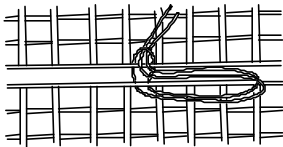

1. START IN CENTER OF TEAR WITH KNOT.

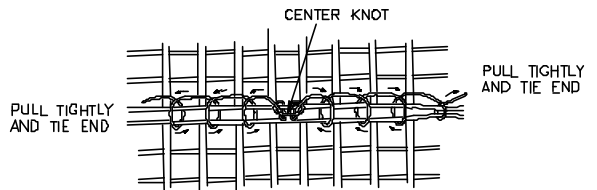

2. WIND ONE END OF TWINE AWAY FROM CENTER KNOT PULL TIGHTLY AND TIE KNOT AT END OF TWINE. REPEAT SAME PROCEDURE WITH OTHER END OF TWINE GOING IN THE OPPOSITE DIRECTION.

ULCANS-3-01-0899

Figure 3-1. ULCANS Camouflage Screen Repair (Sheet 1 of 2)



**C** REPAIRING IRREGULAR HOLE OR MISSING GARNISH IN SCREEN.

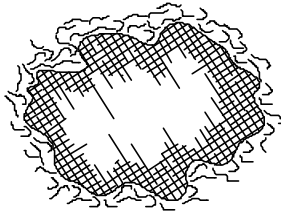

1. TRIM RAGGED EDGES OF HOLE MAKING A SQUARE OR CIRCLE, WHICHEVER CONFIGURATION LENDS ITSELF BEST.

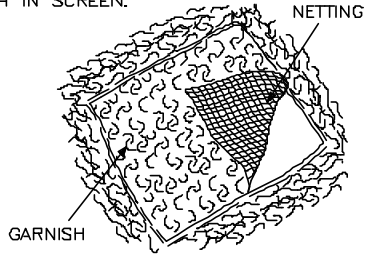

2. AFTER TRIMMING RAGGED EDGES CUT PATCH FROM REPAIR MATERIAL AND REPLACE TORN AREA. PROCEED TO SECURE REPLACED MATERIAL WITH TIEDOWN STRAP OR TWINE

**D** IN THE EVENT MULTIPLE BECKETS ARE MISSING OR BROKEN, BECKET CAN BE REPLACED WITH A TIEDOWN STRAP OR TWINE.

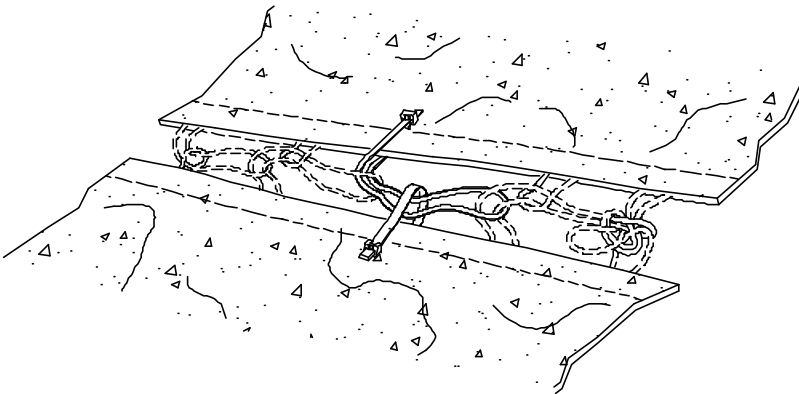

ULCANS-3-01A-0200

Figure 3-1. ULCANS Camouflage Screen Repair (Sheet 2 of 2)

**APPENDIX A  
REFERENCES**

**SCOPE**

This appendix lists all forms, field manuals, technical manuals and miscellaneous publications referenced in this manual.

**FORMS**

- DA Form 2028 ..... Recommended Changes to Publications and Blank Forms
- DA Form 2028-2..... Recommended Changes to Equipment Technical Publications
- SF Form 361 .....Transportation Discrepancy Report
- SF Form 364 ..... Report of Discrepancy
- SF Form 368 ..... Product Quality Deficiency Report

**MISCELLANEOUS PUBLICATIONS**

- AR 55-38 .....Reporting of Transportation Discrepancies in Shipments
- AR 735-11-2 ..... Reporting of Supply Discrepancies
- DA Pam 25-30 ..... Consolidated Index of Army Publications and Blank Forms
- DA Pam 738-750 ..... Functional Users Manual for the Army  
..... Maintenance Management System (TAMMS)
- FM 20-3 ..... Camouflage, Concealment, and Decoys

**TECHNICAL MANUALS**

- TB 43-0002-42 ..... Maintenance Expenditure Limits for FSC 1080
- TM 750-244-3 ..... Procedures for Destruction of Equipment to Prevent Enemy Use

## APPENDIX B

### MAINTENANCE ALLOCATION CHART (MAC)

#### Section I. INTRODUCTION

##### **B-1. The Army Maintenance System MAC.**

This introduction provides a general explanation of all maintenance and repair functions authorized at the two maintenance levels under the Two-Level Maintenance System concept.

This MAC (immediately following the introduction) designates overall authority and responsibility for the performance of maintenance functions on the identified end item or component. The application of the maintenance functions to the end item or component shall be consistent with the capacities and capabilities of the designated maintenance levels, which are shown on the MAC in column (4) as:

- Field – includes two subcolumns, Crew (C) and Maintainer (F).
- Sustainment – includes two subcolumns, Below Depot (H) and Depot (D)

The maintenance to be performed at field and sustainment levels is described as follows:

1. **Crew maintenance.** The responsibility of the using organization to perform maintenance on the assigned equipment. It normally consists of inspecting, servicing, lubricating, adjusting, and replacing parts, minor assemblies, and subassemblies. The replace function for this level of maintenance is indicated by the letter "C" in the third position of the SMR code. An "C" appearing in the fourth position of the SMR code indicates complete repair is possible at the service maintenance level.
2. **Maintainer Maintenance.** Maintenance accomplished on a component, accessory, assembly, subassembly, plug-in unit, or other portion either on the system or after it is removed. The replace function for this level of maintenance is indicated by the letter "F" appearing in the third position of the SMR code. An "F" appearing in the fourth position of the SMR code indicates complete repair is possible at the field maintenance level. Items are returned to the user after maintenance is performed at this level.
3. **Below Depot Sustainment.** Maintenance accomplished on a component, accessory, assembly, subassembly, plug-in unit, or other portion either on the system or after it is removed. The replace function for this level of maintenance is indicated by the letter "H" appearing in the third position of the SMR code. An "H" appearing in the fourth of the SMR code indicates complete repair is possible

at the below depot sustainment maintenance level. Items are returned to the supply system after maintenance is performed at this level.

4. **Depot Sustainment.** Maintenance accomplished on a component, accessory, assembly, subassembly, plug-in unit, or other portion either on the system or after it is removed. The replace function for this level of maintenance is indicated by the letter "D" or "K" appearing in the third position of the SMR code. Depot sustainment maintenance can be performed by either depot personnel or contractor personnel. A "D" or "K" appearing in the fourth position of the SMR code indicates complete repair is possible at the depot sustainment maintenance level. Items are returned to the supply systems after maintenance is performed at this level.

The tools and test equipment requirements (immediately following the MAC) list the tools and test equipment (both special tools and common tool sets) required for each maintenance function as referenced from the MAC.

The remarks (immediately following the tools and test equipment requirements) contain supplemental instructions and explanatory notes for a particular maintenance function.

## **B-2. Maintenance Functions.**

Maintenance functions are limited to and defined as follows:

1. **Inspect.** To determine the serviceability of an item by comparing its physical, mechanical, and/or electrical characteristics with established standards through examination (e.g., by sight, sound, or feel). This includes scheduled inspection and gagings and evaluation of cannon tubes.
2. **Test.** To verify serviceability by measuring the mechanical, pneumatic, hydraulic, or electrical characteristics of an item and comparing those characteristics with prescribed standards on a scheduled basis, i.e., load testing of lift devices and hydrostatic testing of pressure hoses.
3. **Service.** Operations required periodically to keep an item in proper operating condition; e.g., to clean (includes decontaminate, when required), to preserve, to drain, to paint, or to replenish fuel, lubricants, chemical fluids, or gases. This includes scheduled exercising and purging of recoil mechanisms. The following are examples of service functions:
  - a. Unpack. To remove from packing box for service or when required for the performance of maintenance operations.
  - b. Repack. To return item to packing box after service and other maintenance operations.
  - c. Clean. To rid the item of contamination.

- d. Touch up. To spot paint scratched or blistered surfaces.
  - e. Mark. To restore obliterated identification.
4. **Adjust.** To maintain or regulate, within prescribed limits, by bringing into proper position, or by setting the operating characteristics to specified parameters.
5. **Align.** To adjust specified variable elements of an item to bring about optimum or desired performance.
6. **Calibrate.** To determine and cause corrections to be made or to be adjusted on instruments of test, measuring, and diagnostic equipment used in precision measurement. Consists of comparisons of two instruments, one of which is a certified standard of known accuracy, to detect and adjust any discrepancy in the accuracy of the instrument being compared.
7. **Remove/Install.** To remove and install the same item when required to perform service or other maintenance functions. Install may be the act of emplacing, seating, or fixing into position a spare, repair part, or module (component or assembly) in a manner to allow the proper functioning of an equipment or system.
8. **Paint** (ammunition only). To prepare and spray color coats of paint so that the ammunition can be identified and protected. The color indicating primary use is applied, preferably, to the entire exterior surface as the background color of the item. Other markings are to be repainted as original so as to retain proper ammunition identification.
9. **Replace.** To remove an unserviceable item and install a serviceable counterpart in its place. "Replace" is authorized by the MAC and assigned maintenance level is shown as the third position code of the Source, Maintenance and Recoverability (SMR) code.
10. **Repair.** The application of maintenance services, including fault location/troubleshooting, removal/installation, disassembly/assembly procedures, and maintenance actions to identify troubles and restore serviceability to an item by correcting specific damage, fault, malfunction, or failure in a part, subassembly, module (component or assembly), end item, or system.

#### NOTE

The following definitions are applicable to the "repair" maintenance function: Services. Inspect, test, service, adjust, align, calibrate, and/or replace.

Fault location/troubleshooting. The process of investigating and detecting the cause of equipment malfunctioning; the act of isolating a fault within a system or Unit Under Test (UUT).

Disassembly/assembly. The step-by-step breakdown (taking apart) of a spare/functional group coded item to the level of its least component, and that is assigned an SMR code for the level of maintenance under consideration (i.e., identified as maintenance significant).

Actions. Welding, grinding, riveting, straightening, facing, machining, and/or resurfacing.

11. **Overhaul.** That maintenance effort (service/action) prescribed to restore an item to a completely serviceable/operational condition as required by maintenance standards in appropriate technical publications. Overhaul is normally the highest degree of maintenance performed by the Army. Overhaul does not normally return an item to like new condition.

12. **Rebuild.** Consists of those services/actions necessary for the restoration of unserviceable equipment to a like new condition in accordance with original manufacturing standards. Rebuild is the highest degree of materiel maintenance applied to Army equipment. The rebuild operation includes the act of returning to zero those age measurements (e.g., hours/miles) considered in classifying Army equipment/components.

### **B-3. Explanation of Columns in the MAC, Section II.**

Column (1) **Group Number.** Column (1) lists Functional Group Code (FGC) numbers, the purpose of which is to identify maintenance significant components, assemblies, subassemblies, and modules with the Next Higher Assembly (NHA).

Column (2) **Component/Assembly.** Column (2) contains the item names of components, assemblies, subassemblies, and modules for which maintenance is authorized.

Column (3) **Maintenance Function.** Column (3) lists the functions to be performed on the item listed in column (2). (For a detailed explanation of these functions refer to "Maintenance Functions" outlined above).

Column (4) **Maintenance Level.** Column (4) specifies each level of maintenance authorized to perform each function listed in column (3), by indicating work time required (expressed as manhours in whole hours or decimals) in the appropriate subcolumn. This work time figure represents the active time required to perform that maintenance function at the indicated level of maintenance. If the number or complexity of the tasks within the listed maintenance function varies at different

maintenance levels, appropriate work time figures are to be shown for each level. The work time figure represents the average time required to restore an item (assembly, subassembly, component, module, end item, or system) to a serviceable condition under typical field operating conditions. This time includes preparation time (including any necessary disassembly/assembly time), troubleshooting/fault location time, and quality assurance time in addition to the time required to perform the specific tasks identified for the maintenance functions authorized in the MAC. The symbol designations for the various maintenance levels are as follows:

Field: C Crew maintenance  
 F Maintainer maintenance

Sustainment:

L Specialized Repair Activity (SRA)  
 H Below Depot maintenance  
 D Depot maintenance

**NOTE**

The “L” maintenance level is not included in column (4) of the MAC. Functions to this level of maintenance are identified by work time figure in the “H” column of column (4), and an associated reference code is used in the REMARKS column (6). This code is keyed to the remarks and the SRA complete repair application is explained there.

Column (5) **Tools and Equipment Reference Code.** Column (5) specifies, by code, those common tool sets (not individual tools), common Test, Measurement and Diagnostic Equipment (TMDE), and special tools, special TMDE and special support equipment required to perform the designated function. Codes are keyed to the entries in the tools and test equipment table.

Column (6) **Remarks Code.** When applicable, this column contains a letter code, in alphabetical order, which is keyed to the remarks table entries.

**B-4. Explanation of Columns in the Tools and Test Equipment Requirements, Section III.**

Column (1) Tool or Test Equipment Reference Code. The tool or test equipment reference code correlates with a code used in Column (5) of the MAC,

Column (2) Maintenance Level. The lowest level of maintenance authorized to use the tool or test equipment.

Column (3) Nomenclature. Name or identification of the tool or test equipment.

Column (4) National Stock Number (NSN). The NSN of the tool or test equipment.

Column (5) Tool Number. The manufacturer's part number.

**B-5. Explanation of Columns in Remarks, Section IV.**

Column (1) Remarks Code. The code recorded in column (6) of the MAC.

Column (2) Remarks. This column lists information pertinent to the maintenance function being performed as indicated in the MAC.



**Table 1. MAINTENANCE ALLOCATION CHART  
FOR  
ULTRALIGHTWEIGHT CAMOUFLAGE NET SYSTEM (ULCANS)**

(1) GROUP NUMBER	(2) COMPONENT/ ASSEMBLY	(3) MAINT- ENANCE FUNCTION	(4) MAINTENANCE LEVEL				(5) TOOLS AND EQUIPMENT REF CODE	(6) REMARKS CODE
			FIELD		SUSTAINMENT			
			CREW	MAINTAINER	BELOW DEPOT	DEPOT		
			C	F	H	D		
00 *	Ultralightweight Camouflage Net System (ULCANS), General Purpose, Types III and IV, Class 1 and 2	INSPECT REPAIR INSPECT	0.5 0.5 0.5				A B C	
01	Camouflage Screening System	REPLACE REPAIR	0.5 0.1				A C	
0101	Screen, Camouflage (Hexagon)	INSPECT REPLACE REPAIR	0.1 0.1 0.1				A B C	
0102	Screen, Camouflage (Rhombic)	INSPECT REPLACE REPAIR	0.1 0.1 0.1				A B C	
0103	Repair Kit, Types III and IV, Class 1 and 2 Contents:	INSPECT REPAIR REPLACE	0.1 0.1 0.1				A B C	
010301	Case, Carrying (Repair Kit), (1 ea.)	REPLACE	0.1				B	
010302	Cloth, Camouflage (25 sq. ft.)	REPLACE	0.1				B	
010303	Strap, Tiedown, Electrical Components, (300 ea.)	REPLACE	0.1				B	
0104	Case, Carrying (Screen System)	REPLACE	0.1				B	

\* Includes all variants.

(1) GROUP NUMBER	(2) COMPONENT/ ASSEMBLY	(3) MAINT- ENANCE FUNCTION	(4) MAINTENANCE LEVEL				(5) TOOLS AND EQUIPMENT REF CODE	(6) REMARKS CODE
			FIELD		SUSTAINMENT			
			CREW	MAINTAINER	BELOW DEPOT	DEPOT		
			C	F	H	D		
02	Support, Camouflage	INSPECT REPAIR	0.2 0.2				A C	
0201	Case, Carrying (Support)	INSPECT REPLACE	0.1 0.1				A B	
0202	Bag, Textile (Stakes)	INSPECT REPLACE	0.1 0.1				A B	
0203	Stakes, Camouflage Aluminum	INSPECT REPLACE	0.1 0.1				A B	
0204	Pole, Support, Aluminum	INSPECT REPLACE REPAIR	0.1 0.1 0.1				A B C	
0205	Shape Disrupter	INSPECT REPLACE	0.1 0.1				A B	

**TOOLS AND TEST EQUIPMENT REQUIREMENTS  
FOR  
ULTRALIGHTWEIGHT CAMOUFLAGE NET SYSTEM (ULCANS)  
(NOT APPLICABLE)**

Tool or Test Equipment Reference Code	Maintenance Category	Nomenclature	National/NATO Stock NUMBER	Tool Number
N/A *				

\* See Appendix E, Additional Authorization List (AAL).

**REMARKS**

REFERENCE CODE	REMARKS
A	<p>Inspect by checking the following:</p> <ul style="list-style-type: none"> <li>• Inventory contents and check serviceability of screen carrying case with components) (Chapter 2, Operating Instructions, Figure 2-2).</li> <li>• Inventory contents and check serviceability of support system carrying case (with components) (Chapter 2, Operating Instructions, Figure 2-2).</li> </ul>
B	<p>Replace broken, missing, or unserviceable items immediately through normal supply channels.</p> <ul style="list-style-type: none"> <li>• Replace broken shape disrupters; bent, broken, or unusable support poles and stake anchors.</li> <li>• Replace unrepairable screen modules.</li> <li>• Replace contents of repair kit as necessary.</li> </ul>
C	<p>Repair screens and support system items as necessary in accordance with Chapter 3, Maintenance Instructions.</p> <ul style="list-style-type: none"> <li>• Repair screen modules using contents of repair kit in accordance with Chapter 3.</li> <li>• Repair aluminum support poles by filing off nicks or burrs, and spot painting as necessary in accordance with Chapter 3.</li> </ul>
D	<p>Crew maintenance will inspect to determine serviceability before disposal. To determine serviceability: inspect the garnish, base, net and edge cord for materials that have deteriorated and can be easily torn. If one or more of the following conditions exists, the net should be turned in to PDO:</p> <ul style="list-style-type: none"> <li>• The net can be easily broken in numerous places.</li> <li>• The garnish is dried out and brittle, or 25% of the garnish is broken away and hanging in a vertical position from the net.</li> <li>• The edge cord has broken away from the net in numerous places and cannot be reattached to a weak or deteriorated net.</li> <li>• The net has been repeatedly repaired and cannot be supported by the support system.</li> <li>• Maintenance Expenditure Limits for camouflage reach 65% of replacement costs to include material and labor. (Refer to TB 43-0002-42).</li> </ul>

**APPENDIX C****REPAIR PARTS AND SPECIAL TOOLS LIST****Section I. INTRODUCTION****C-1. SCOPE.**

This manual lists and authorizes spares and repair parts; special tools; special test, measurement, and diagnostic equipment (TMDE); and other special support equipment required for the performance of Operator and Unit Level Maintenance of the Ultralightweight Camouflage Net System (ULCANS). It authorizes the requisitioning, issue, and disposition of spares, repair parts, and special tools as indicated by the source, maintenance, and recoverability (SMR) codes.

**C-2. GENERAL.**

This Repair Parts and Special Tools List is divided into the following sections:

- a. Section II. Repair Parts List. A list of spares and repair parts authorized by this RPSTL for use in the performance of maintenance. This list also includes parts which must be removed for replacement of the authorized parts. Parts list are composed of functional groups in ascending alphanumeric sequence, with the parts in each group listed in ascending figure and item number sequence. Bulk materials are listed in item name sequence. Repair part kits are listed separately in their own functional group within Section II. Repair parts of reparable special tools are also listed in this section. Items listed are shown on the associated illustration(s)/figure(s).
- b. Section III. Special Tools List. A list of special tools, special TMDE, and other special support equipment authorized by this RPSTL (as indicated by Basis of Issue (BOI) information in DESCRIPTION AND USUSABLE ON CODE column(Column (6)) for the performance of maintenance.
- c. Section IV. Cross-Reference Indexes. A list, in National Item Identification Number (NIIN) sequence, of all National Stock Numbered items appearing in the listing, followed by a list in alpha-numeric sequence of all Part Numbers appearing in the listings. National Stock Numbers and Part Numbers are cross-referenced to each illustration figure and item number appearance.

**C-3. EXPLANATION OF COLUMNS (Section II and III).**

- a. Item No. (Column (1)). Indicates the number used to identify items called out in the illustrations.
- b. SMR Code (Column (2)). The source, maintenance, and recoverability (SMR) code is a five-position code containing supply/requisitioning information, maintenance category authorization criteria and disposition instruction, as shown in the following breakout:

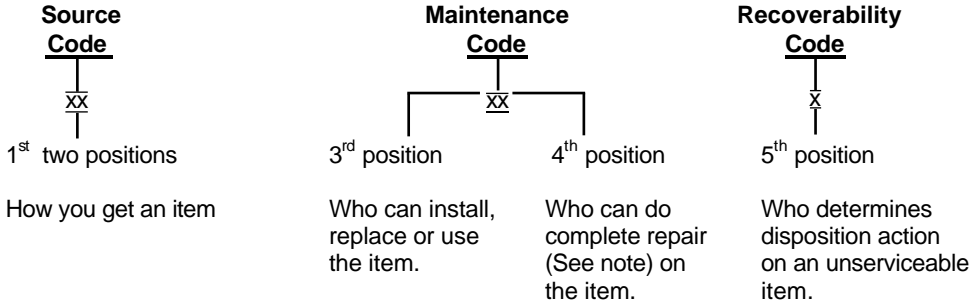

**NOTE**

Complete repair: Maintenance capacity, capability, and authority to perform all corrective maintenance tasks of the "repair" function in a use/user environment in order to restore serviceability to a failed item.

- (1) Source Code. The source code tells you how to get an item needed for maintenance, repair, or overhaul of an end item/equipment. Explanations of source codes follows:

<b>Code</b>	<b>Explanation</b>
-------------	--------------------

PA PB PC PD PE PF PG	Stocked Items: Use the applicable NSN to request/requisition items with these source codes. They are authorized to the category indicated by the code entered in the third position of the SMR code.
<p><b>NOTE</b></p> Items coded PC are subject to deterioration	

KD KF KB	Items with these codes are not to be requested/requisitioned individually. They are part of a kit which is authorized to the maintenance category indicated in the third position of the SMR code. The complete kit must be requisitioned and applied.
----------------	--

MO - Made at org/ AVUM category MF - Made at DS/AVIM category MH - Made at GS category ML - Made at Specialized Repair Activity (SRA) MD - Made at Depot	Items with these codes are not to be requested/requisitioned individually. They must be made from bulk material which is identified by the Part Number in the DESCRIPTION AND USABLE ON CODE (UOC) column and listed in the Bulk Material group of the repair parts list. If the item is authorized to you by the 3rd position code of the SMR code, but the source code indicates it is made at a higher category, order the item from the higher level of maintenance.
---	--

Code	Explanation
AO - Assembled by org/ AF - Assembled by DS/ AH - Assembled by GS category AL - Assembled by SRA AD - Assembled by Depot	Items with these codes are not to be requested/requisitioned individually. The parts that make up the assembled item must be requisitioned or fabricated and assembled at the category of maintenance indicated by the source code. If the 3rd position code of the SMR code authorizes you to replace the item, but the source code indicates the item is assembled at a higher category, order the item from the higher level of maintenance.

Code	Explanation
XA -	Do not requisition an "XA"-coded item. Order its next higher assembly. (Refer to the NOTE below).
XB -	If an "XB" item is not available from salvage, order it using the CAGEC and Part Number given.
XC -	Installation drawing, diagram, instruction sheet, field service drawing, that is identified by manufacturer's part number
XD -	Item is not stocked. Order an "XD"-coded item through normal supply channels using the CAGEC and Part Number given, if no NSN is available.

**NOTE**

Cannibalization or controlled exchange, when authorized, may be used as a source of supply for items with the above source codes, except for those source coded "XA" or those aircraft support items restricted by requirements of AR 750-1.

- (2) Maintenance Code. Maintenance codes tell you the levels of maintenance authorized to USE and REPAIR support items. The maintenance codes are entered in the third and fourth positions of the SMR code as follows:
  - (a) The maintenance code entered in the third position tells you the lowest maintenance category authorized to remove, replace, and use an item. The maintenance code entered in the third position will indicate authorization to one of the following categories of maintenance.

Code	Application/Explanation
C -	Crew or operator maintenance done within unit AVUM maintenance.
O -	Unit level /AVUM maintenance can remove, replace, and use the item.
F -	Direct support/AVIM maintenance can remove, replace, and use the item.
H -	General support maintenance can remove, replace, and use the item.
L -	Specialized repair activity can remove, replace, and use the item.
D -	Depot can remove, replace, and use the item.
(b)	The maintenance code entered in the fourth position tells whether or not the item is to be repaired and identifies the lowest maintenance level with the capability to do complete repair (i.e., perform all authorized repair functions). (NOTE: Some limited repair may be done on the item at a lower category of maintenance, if authorized by the Maintenance Allocation Chart (MAC) and SMR codes.) This position will contain one of the following maintenance codes.

<b>Code</b>	<b>Application/Explanation</b>
O -	Unit/AVUM is the lowest level that can do complete repair of the item.
F -	Direct support/AVIM is the lowest level that can do complete repair of the item.
H -	General support is the lowest level that can do complete repair of the item.
L -	Specialized repair activity is the lowest level that can do complete repair of the item.
D -	Depot is the lowest level that can do complete repair of the item.
Z -	Nonreparable. No repair is authorized.
B -	No repair is authorized. (No parts or special tools are assigned for the maintenance of a "B" coded item.) However, the item may be reconditioned by adjusting, lubricating, etc., at the user level.

- (3) Recoverability Code. Recoverability codes are assigned to items to indicate the disposition action on unserviceable items. The recoverability code is entered in the fifth position of the SMR code as follows:

**Recoverability**

<b>Code</b>	<b>Application/Explanation</b>
Z -	Nonreparable item. When unserviceable, condemn and dispose of the item at the level of maintenance shown in the third position of the SMR code.
O -	Reparable item. When uneconomically repairable, condemn and dispose of the item at unit level.
F -	Reparable item. When uneconomically repairable, condemn and dispose of the item at direct support level.
H -	Reparable item. When uneconomically repairable, condemn and dispose of the item at general support level.
D -	Reparable item. When beyond lower level repair capability, return to depot. Condemnation and disposal of the item not authorized below depot level.
L -	Reparable Item. Condemnation and disposal of item not authorized below Specialized Repair Activity (SRA).
A -	Item requires special handling or condemnation procedures because of specific reasons (e.g., precious metal content, high dollar value, critical material, or hazardous material). Refer to appropriate manual/directives for specific instructions.

- c. NATIONAL STOCK NUMBER (Column (3)). The National Stock Number assigned to the item is listed in this column.
- d. CAGEC (Column (4)). The Commercial and Governmental Entity Code (CAGEC) is a 5-character alphanumeric code used to identify the manufacturer, distributor, or Government agency, etc., that supplies the item.
- e. Part Number (Column (5)). Indicates the primary number used by the manufacturer (individual, company, firm, corporation, or Government activity), which controls the design and characteristics of the item by means of its engineering drawings, specifications, standards and inspection requirements to identify an item or range of items.

**NOTE**

When you use an NSN to requisition an item, the item you receive may have a different Part Number (P/N) from the part ordered.



- f. Description and Usable on Code (UOC) (Column (6)). This column includes the following information:
  - (1) The Federal item name and, when required, a minimum description to identify the item.
  - (2) Usable on Code, when applicable (See para. 5, Special Information).
  - (3) The statement "END OF FIGURE" appears just below the last item description in Column (6) for a given figure in both Section II and Section III.
- g. QTY (Column 7). The QTY (quantity per figure) indicates the quantity of the item used in the breakout shown on the illustration/figure, which is prepared for a functional group, subfunctional group, or an assembly. A "V" appearing in this column in lieu of a quantity indicates that the quantity is variable and the quantity may vary from application to application.

**C-4. EXPLANATION OF THE INDEX FORMAT AND COLUMNS (Section IV).**

- a. National Stock Number (NSN) Index.
  - (1) Stock Number Column. This column lists the NSN by National item identification number (NIIN) sequence. The NIIN consists of the last nine digits of the NSN. When requisitioning items use the complete NSN (13 digits).
 

$\begin{array}{c} \text{——NSN——} \\ \text{(e.g., 5385-01-574-1476)} \\ \text{——NIIN——} \end{array}$	When using this column to locate an item, ignore the first four digits of the NSN. However, the complete NSN should be used when ordering items by stock number.
---	--
  - (2) Fig. Column. This column lists the number of the figure where the item is identified/located. The illustrations are in numerical sequence in Sections II and III.
  - (3) Item Column. The item number identifies the item associated with the figure listed in the adjacent FIG. column. This item is also identified by the NSN listed on the same line.
- b. Part Number (P/N) Index. Part Numbers in this index are listed by Part Number in ascending alphanumeric sequence (i.e., vertical arrangement of letter and number combinations which places the first letter or digit of each group in order A through Z, followed by the numbers 0 through 9 and each following letter or digit in like order).
  - (1) CAGEC Column. This column lists the Commercial and Government Entity (CAGEC) code.
  - (2) Part Number Column. This column indicates the Part Number assigned to the item.
  - (3) Stock Number Column. This column lists the National Stock Number for the associated Part Number and manufacturer identified in the Part Number and CAGEC columns to the left.
  - (4) Fig. Column. This column lists the number of the figure where the item is identified/located in Section II and III.
  - (5) Item Column. The item number is that number assigned to the item as it appears in the figure referenced in the adjacent figure number column.

**C-5. SPECIAL INFORMATION.**

- a. Usable on Code. The usable on code appears in the lower left corner of the Description Column heading. Usable on codes are shown as "UOC:..." in the

## TM 5-1080-250-12&P

Description Column (justified left) on the first line under the applicable item/nomenclature. Uncoded items are applicable to all models. Identification of the usable on codes used in this RPSTL are:

<b>Code</b>	<b>Used On</b>
LQL	Woodland R/S AN/USQ-150
31D	Woodland R/T AN/USQ-160
31E	Desert R/S AN/USQ-159
31F	Desert R/T AN/USQ-158

- b. Associated Publications. Not Applicable
- c. National Stock Numbers. National Stock Numbers (NSN) that are missing from P source coded items have been applied for and will be added to this TM by future change/revision when they are entered in the Army Master Data File (AMDF). Until the NSNs are established and published, submit exception requisitions to: Commander, US Army Communications-Electronic Command and Fort Monmouth, ATTN: AMSEL-LC-LEO-D-CS-CFO, Fort Monmouth, NJ 07703-5006 for the part required to support your equipment.

### C-6. HOW TO LOCATE REPAIR PARTS.

- a. When National Stock Number or Part Number is Not Known.
  - (1) First. Using the table of contents, determine the assembly group or subassembly group to which the item belongs. This is necessary since figures are prepared for assembly groups, subassembly groups, and listings are divided into the same groups.
  - (2) Second. Find the figure covering the assembly group or subassembly group to which the item belongs.
  - (3) Third. Identify the item on the figure and note the item number.
  - (4) Fourth. Refer to the Repair Parts Lists for the figure to find the Part Number for the item number noted on the figure.
  - (5) Fifth. Refer to the Part Number index to find the NSN, if assigned.
- b. When National Stock Number or Part Number is known.
  - (1) First. Using the index of the National Stock Numbers and Part Numbers, find the pertinent National Stock Number or Part Number. The NSN Index is in National Item Identification Number (NIIN) sequence (para 4a (1)). The Part Numbers in the Part Number index are listed in ascending alpha-numeric sequence (para 4b). Both indexes cross-reference you to the illustration figure and item number of the item you are looking for.
  - (2) Second. After finding the figure and item number, verify that the item is the one you're looking for, then locate the item number in the repair parts list for the figure.

### C-7. ABBREVIATIONS.

Not applicable

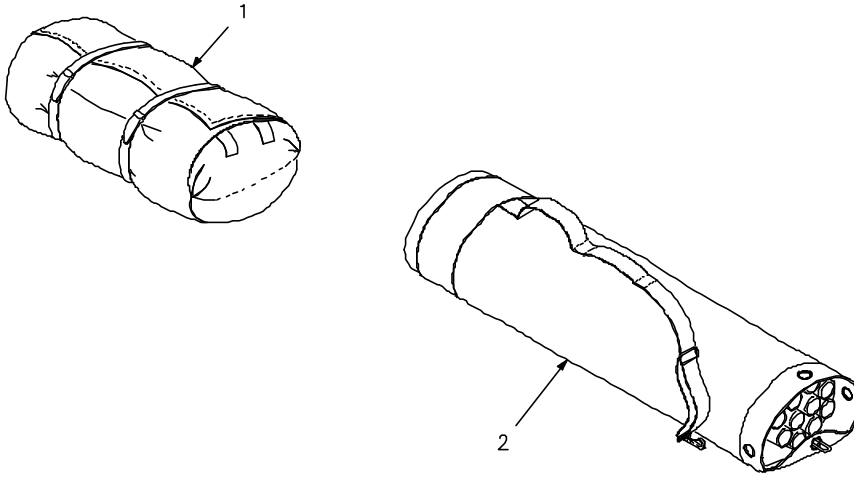

ULCANS-C-01-0699

Figure C-1. ULCANS (Class 1 - Woodland and Class 2 - Desert;  
Type IV (Gp-R/S) and Type III (Gp R/T))

SECTION II

Figure C-1

(1) ITEM NO	(2) SMR CODE	(3) NATIONAL STOCK NUMBER	(4) CAGEC	(5) PART NUMBER	(6) DESCRIPTION AND USABLE ON CODES (UOC) GROUP 00 ULCANS	(7) QTY
1	PAOOO	1080-01-462-0278	19397	186311-0001	CAMOUFLAGE SCREENING SYSTEM (Class 1 – Woodland, Type IV R/S) UOC: LQL	1
1	PAOOO	1080-01-475-1590	19397	191258-0001	CAMOUFLAGE SCREENING SYSTEM (Class 1 – Woodland, Type III R/T) UOC: 31D	1
1	PAOOO	1080-01-475-1592	19397	191226-0001	CAMOUFLAGE SCREENING SYSTEM (Class 2 – Desert, Type IV R/S) UOC: 31E	1
1	PAOOO	1080-01-475-1583	19397	191233-0001	CAMOUFLAGE SCREENING SYSTEM (Class 2 – Desert, Type III R/T) UOC: 31F	1
2	PAOOO	1080-01-463-0046	19397	186312-0001	SUPPORT, CAMOUFLAGE SCREENING SYSTEM	1

END OF FIGURE

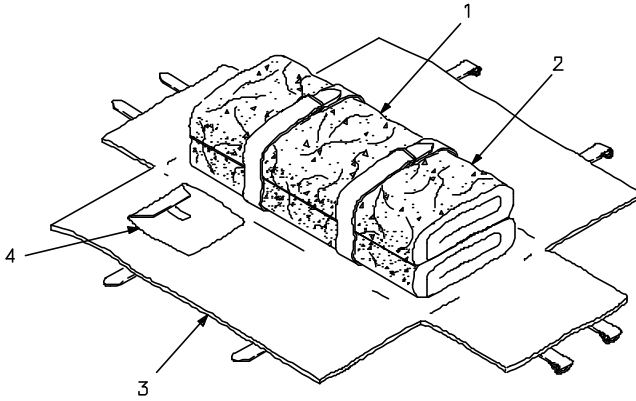

ULCANS-C-02-0699

Figure C-2. Camouflage Screening System

SECTION II

Figure C-2

(1) ITEM NO	(2) SMR CODE	(3) NATIONAL STOCK NUMBER	(4) CAGEC	(5) PART NUMBER	(6) DESCRIPTION AND USABLE ON CODES (UOC) GROUP 01 CAMOUFLAGE SCREENING SYSTEM	(7) QTY
1	PAOOO	1080-01-461-0155	19397	186301-0001	SCREEN, CAMOUFLAGE (Hexagon) UOC: LQL	1
1	PAOOO	1080-01-475-1588	19397	191260-0001	SCREEN, CAMOUFLAGE (Hexagon) UOC: 31D	1
1	PAOOO	1080-01-475-1593	19397	191227-0001	SCREEN, CAMOUFLAGE (Hexagon) UOC: 31E	1
1	PAOOO	1080-01-475-1584	19397	191234-0001	SCREEN, CAMOUFLAGE (Hexagon) UOC: 31F	1
2	PAOOO	1080-01-461-0154	19397	186302-0001	SCREEN, CAMOUFLAGE (Rhombic) UOC: LQL	1
2	PAOOO	1080-01-475-1589	19397	191261-0001	SCREEN, CAMOUFLAGE (Rhombic) UOC: 31D	1
2	PAOOO	1080-01-475-1594	19397	191228-0001	SCREEN, CAMOUFLAGE (Rhombic) UOC: 31E	1
2	PAOOO	1080-01-476-1479	19397	191235-0001	SCREEN, CAMOUFLAGE (Rhombic) UOC: 31F	1
3	PAOZZ	1080-01-461-9330	19397	184093-0001	CASE, Carrying (Screen System) UOC: LQL	1
3	PAOZZ	1080-01-475-1587	19397	184093-0002	CASE, Carrying (Screen System) UOC: 31D	1
3	PAOZZ	1080-01-475-1596	19397	184093-0003	CASE, Carrying (Screen System) UOC: 31E	1
3	PAOZZ	1080-01-475-1585	19397	184093-0004	CASE, Carrying (Screen System) UOC: 31F	1
4	PAOOO	1080-01-463-4081	19397	186303-0001	REPAIR KIT, Camouflage Net Set (See Fig. C-4 for parts breakdown) UOC: LQL	1
4	PAOOO	1080-01-475-1591	19397	191262-0001	REPAIR KIT, Camouflage Net Set (See Fig. C-4 for parts breakdown) UOC: 31E	1
4	PAOOO	1080-01-475-1595	19397	191229-0001	REPAIR KIT, Camouflage Net Set (See Fig. C-4 for parts breakdown) UOC: 31D	1
4	PAOOO	1080-01-475-1586	19397	191236-0001	REPAIR KIT, Camouflage Net Set (See Fig. C-4 for parts breakdown) UOC: 31F	1

END OF FIGURE

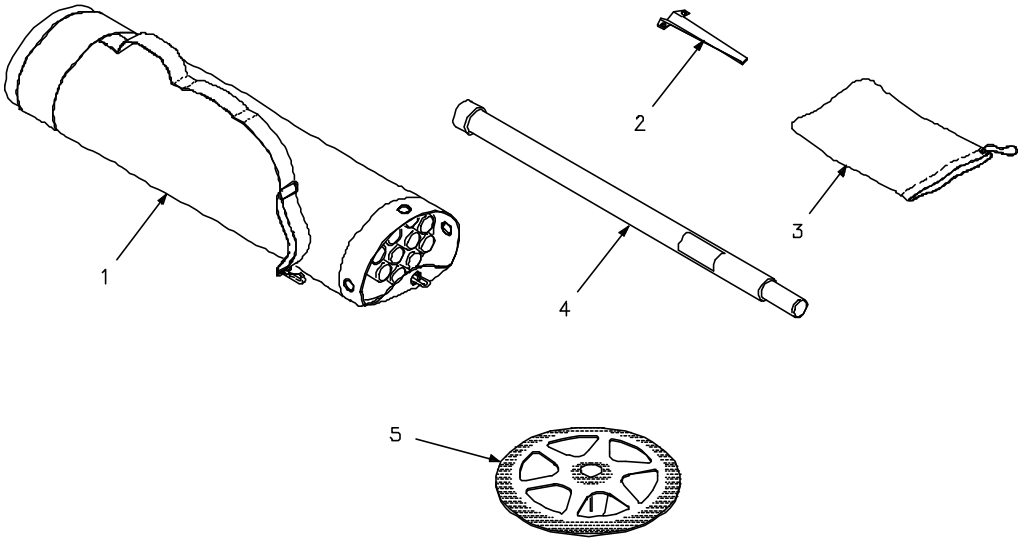

ULCANS-C-04-0699

Figure C-3. Support, Camouflage Screening System

SECTION II

Figure C-3

(1) ITEM NO	(2) SMR CODE	(3) NATIONAL STOCK NUMBER	(3) CAGEC	(4) PART NUMBER	(5) DESCRIPTION AND USABLE ON CODES (UOC) GROUP 02 SUPPORT, CAMOUFLAGE SCREENING SYSTEM	(6) QTY
1	PAOZZ	1080-01-461-0153	19397	184092-0001	CASE, Carrying (Support System for Woodland and Desert)	1
2	PAOZZ	1080-00-108-1654	19397	13227E0136	STAKE, Camouflage, Aluminum	24
3	PAOZZ	8105-01-464-3148	19397	186305-0001	BAG, Textile ( Stakes)	1
4	PAOZZ	1080-01-464-8288	19397	184055-0001	POLE, Support (Woodland and Desert)	12
5	PAOZZ	1080-01-461-0152	19397	184054-0001	SHAPE DISRUPTER (Woodland and Desert)	6

END OF FIGURE



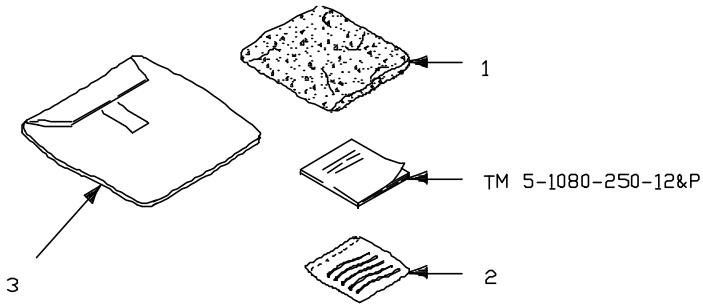

ULCANS-C-03-0699

Figure C-4. Repair Kit, Camouflage Net Set

SECTION II  
Figure C-4

(1) ITEM NO	(2) SMR CODE	(3) NATIONAL STOCK NUMBER	(4) CAGEC	(5) PART NUMBER	(6) DESCRIPTION AND USABLE ON CODES (UOC) GROUP 0103 REPAIR KIT, CAMOUFLAGE NET SET	(7) QTY
1	PAOZZ	8305-01-462-3601	19397	186304-0001	CLOTH, Camouflage (Woodland R/S) (25 SQ FT) UOC: LQL	1
1	PAOZZ	8305-01-474-8352	19397	191263-0001	CLOTH, Camouflage (Woodland R/T) (25 SQ FT) UOC: 31D	1
1	PAOZZ	8305-01-475-1597	19397	191230-0001	CLOTH, Camouflage (Desert R/S) (25 SQ FT) UOC: 31E	1
1	PAOZZ	8305-01-475-5250	19397	191237-0001	CLOTH, Camouflage (Desert R/T) (25 SQ FT) UOC: 31F	1
2	PAOZZ	5975-01-462-3602	19397	186306-0001	STRAP, Tiedown (Plastic) (300 EA)	1
3	PAOZZ	1080-01-461-0156	19397	184091-0001	CASE, Carrying (Repair Kit) UOC: LQL	1
3	PAOZZ	1080-01-497-9332	19397	184091-0003	CASE, Carrying (Repair Kit) UOC: 31D	1
3	PAOZZ	1080-01-497-9333	19397	184091-0002	CASE, Carrying (Repair Kit) UOC: 31E	1
3	PAOZZ	1080-01-497-9334	19397	184091-0004	CASE, Carrying (Repair Kit) UOC: 31F	1

NOTE: TM 5-1080-250-12&P is packed inside the case of the Repair Kit, Camouflage Net Set.

END OF FIGURE

## SECTION IV

## CROSS REFERENCE INDEXES

## NATIONAL STOCK NUMBER INDEX

STOCK NUMBER	FIG.	ITEM
1080-00-108-1654	C-3	2
1080-01-461-0152	C-3	5
1080-01-461-0153	C-3	1
1080-01-461-0154	C-2	2
1080-01-461-0155	C-2	1
1080-01-461-0156	C-4	3
1080-01-461-9330	C-2	3
1080-01-462-0278	C-1	1
5975-01-462-3602	C-4	2
1080-01-463-0046	C-1	2
1080-01-463-4081	C-2	4
1080-01-464-8288	C-3	4
1080-01-475-1583	C-1	1
1080-01-475-1584	C-2	1
1080-01-475-1585	C-2	3
1080-01-475-1586	C-2	4
1080-01-475-1587	C-2	3
1080-01-475-1588	C-2	1
1080-01-475-1589	C-2	2
1080-01-475-1590	C-1	1
1080-01-475-1591	C-2	4
1080-01-475-1592	C-1	1
1080-01-475-1593	C-2	1
1080-01-475-1594	C-2	2
1080-01-475-1595	C-2	4
1080-01-475-1596	C-2	3
1080-01-476-1479	C-2	2
1080-01-497-9332	C-4	3
1080-01-497-9333	C-4	3
1080-01-497-9334	C-4	3
8105-01-464-3148	C-3	3
8305-01-462-3601	C-4	1
8305-01-474-8352	C-4	1
8305-01-475-1597	C-4	1
8305-01-475-5250	C-4	1

**SECTION IV**  
**CROSS REFERENCE INDEXES**

**PART NUMBER INDEX**

<b>CAGEC</b>	<b>PART NUMBER</b>	<b>STOCK NUMBER</b>	<b>FIG.</b>	<b>ITEM</b>
19397	13227E0136	1080-00-108-1654	C-3	2
19397	184054-0001	1080-01-461-0152	C-3	5
19397	184055-0001	1080-01-464-8288	C-3	4
19397	184091-0001	1080-01-461-0156	C-4	3
19397	184091-0002	1080-01-497-9333	C-4	3
19397	184091-0003	1080-01-497-9332	C-4	3
19397	184091-0004	1080-01-497-9334	C-4	3
19397	184092-0001	1080-01-461-0153	C-3	1
19397	184093-0001	1080-01-461-9330	C-2	3
19397	184093-0002	1080-01-475-1587	C-2	3
19397	184093-0003	1080-01-475-1596	C-2	3
19397	184093-0004	1080-01-475-1585	C-2	3
19397	186301-0001	1080-01-461-0155	C-2	1
19397	186302-0001	1080-01-461-0154	C-2	2
19397	186303-0001	1080-01-463-4081	C-2	4
19397	186304-0001	8305-01-462-3601	C-4	1
19397	186305-0001	8105-01-464-3148	C-3	3
19397	186306-0001	5975-01-462-3602	C-4	2
19397	186311-0001	1080-01-462-0278	C-1	1
19397	186312-0001	1080-01-463-0046	C-1	2
19397	191226-0001	1080-01-475-1592	C-1	1
19397	191227-0001	1080-01-475-1593	C-2	1
19397	191228-0001	1080-01-475-1594	C-2	2
19397	191229-0001	1080-01-475-1595	C-2	4
19397	191230-0001	8305-01-475-1597	C-4	1
19397	191233-0001	1080-01-475-1583	C-1	1
19397	191234-0001	1080-01-475-1584	C-2	1
19397	191235-0001	1080-01-476-1479	C-2	2
19397	191236-0001	1080-01-475-1586	C-2	4
19397	191237-0001	8305-01-475-5250	C-4	1
19397	191258-0001	1080-01-475-1590	C-1	1
19397	191260-0001	1080-01-475-1588	C-2	1
19397	191261-0001	1080-01-475-1589	C-2	2
19397	191262-0001	1080-01-475-1591	C-2	4
19397	191263-0001	8305-01-474-8352	C-4	1

## APPENDIX D

## COMPONENTS OF END ITEM AND BASIC ISSUE ITEMS LIST

## Section I. INTRODUCTION

**D-1. Scope.**

This appendix identifies integral components and basic issue items of the Ultralightweight Camouflage Net System (ULCANS) to help you inventory items required for safe and efficient operation of the equipment.

**D-2. General.**

The COEIL and BII information is divided into the following lists.

Components of End Item (COEI). This list is for information purposes only and is not authority to requisition replacements. These items are part of the Ultralightweight Camouflage Net System (ULCANS). As part of the end item, these must be with the end item whenever it is issued or transferred between property accounts. Items of COEI are removed and separately packaged for transportation or shipment only when necessary. Illustrations are furnished to help you find and identify the items.

Basic Issue Items (BII). These essential items are required to place the ULCANS in operation, to operate it, and to do emergency repairs. Although shipped separately packaged, BII must be with the ULCANS during operation and when it is transferred between property accounts. Listing these items is your authority to request/requisition them for replacement based on authorization of the end item by the TOE/MTOE. Illustrations are furnished to help you find and identify the items.

**D-3. Explanation of Columns.**

Column (1), Illus Number: Gives you the number of the item illustrated.

Column (2), National Stock Number (NSN): Identifies the stock number of the item to be used for requisitioning purposes.

Column (3), Description, CAGEC, and Part Number: Identifies the Federal item name (in all capital letters) followed by a minimum description when needed. The stowage location of COEI and BII is also included in this column. The last line below the description is the CAGEC (Commercial and Government Entity Code) (in parentheses) and the part number.

Column (4), Usable on Code: Gives you a code if the item you need is not the same for different models of equipment. These codes are identified below:

<u>CODE</u>	<u>USED ON</u>
LQL	Woodland R/S AN/USQ-150
31D	Woodland R/T AN/USQ-160
31E	Desert R/S AN/USQ-159
31F	Desert R/T AN/USQ-158

**TM 5-1080-250-12&P**

Column (5), U/M (Unit of Measure): Indicates how the item is issued for the National Stock Number shown in Column (2)

Column (6) Qty Rqr: Indicates the quantity required.

CAMOUFLAGE SCREENING SYSTEM

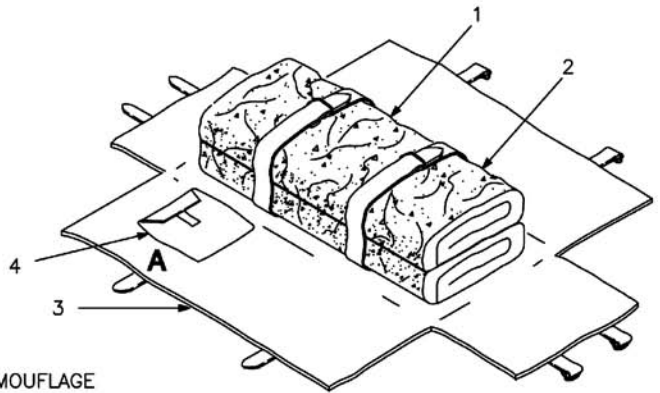
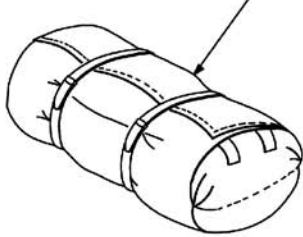

**DETAIL A**  
(REPAIR KIT AND CONTENTS)

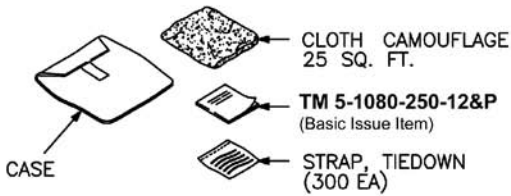

SUPPORT, CAMOUFLAGE SCREENING SYSTEM

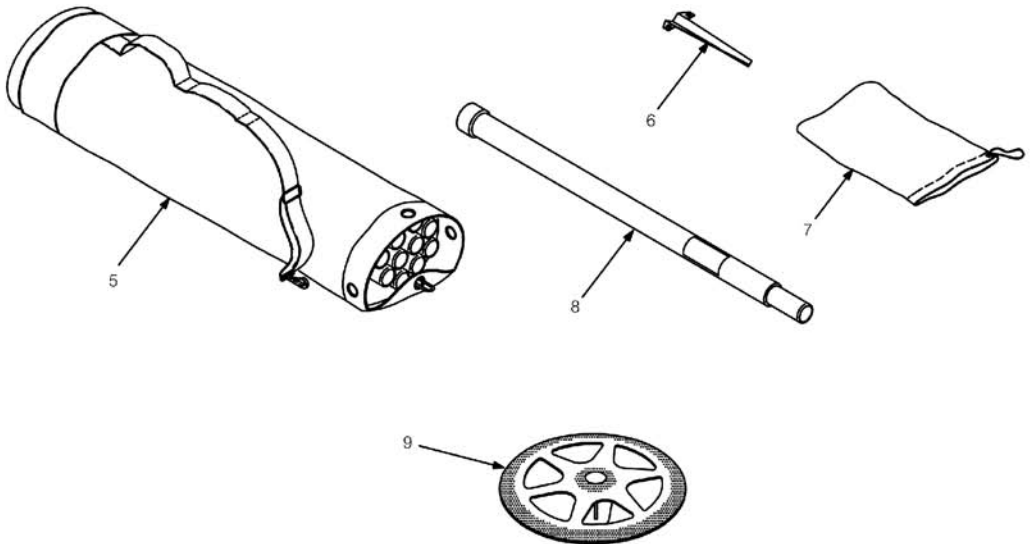

ULCANS-D-01-0699

Figure D-1. ULCANS Components, Group 00

Section II. COMPONENTS OF END ITEM – Continued

(1) ILLUS NUMBER	(2) NATIONAL STOCK NUMBER	(3) DESCRIPTION, CAGEC, AND PART NUMBER	(4) USABLE ON CODE	(5) U/M	(6) QTY RQR
	1080-01-462-0278	CAMOUFLAGE SCREENING SYSTEM (Class 1 – Woodland, Type IV R/S) (19397) 186311-0001	LQL	EA	1
1	1080-01-461-0155	SCREEN, CAMOUFLAGE (Hexagon) (19397) 186301-0001	LQL	EA	1
2	1080-01-461-0154	SCREEN, CAMOUFLAGE (Rhombic) (19397) 186302-0001	LQL	EA	1
3	1080-01-461-9330	CASE, Carrying (Screen System) (19397) 184093-0001	LQL	EA	1
4	1080-01-463-4081	REPAIR KIT, Camouflage Net Set (19397) 186303-0001	LQL	EA	1
Detail A	8305-01-462-3601	CLOTH, Camouflage (Woodland R/S) (25 SQ FT) (19397) 186304-0001	LQL	EA	1
Detail A	1080-01-461-0156	CASE, Carrying (Repair Kit) (19397) 184091-0001	LQL	EA	1
	1080-01-475-1590	CAMOUFLAGE SCREENING SYSTEM (Class 1 – Woodland, Type III R/T) (19397) 191258-0001	31D	EA	1
1	1080-01-475-1588	SCREEN, CAMOUFLAGE (Hexagon) (19397) 191260-0001	31D	EA	1
2	1080-01-475-1589	SCREEN, CAMOUFLAGE (Rhombic) (19397) 191261-0001	31D	EA	1
3	1080-01-475-1587	CASE, Carrying (Screen System) (19397) 184093-0002	31D	EA	1
4	1080-01-475-1591	REPAIR KIT, Camouflage Net Set (19397) 191229-0001	31D	EA	1
Detail A	8305-01-474-8352	CLOTH, Camouflage (Woodland R/T) (25 SQ FT) (19397) 191263-0001	31D	EA	1
Detail A	1080-01-497-9332	CASE, Carrying (Repair Kit) (19397) 184091-0003	31D	EA	1
	1080-01-475-1592	CAMOUFLAGE SCREENING SYSTEM (Class 2 – Desert, Type IV R/S) (19397) 191226-0001	31E	EA	1
1	1080-01-475-1593	SCREEN, CAMOUFLAGE (Hexagon) (19397) 191227-0001	31E	EA	1
2	1080-01-475-1594	SCREEN, CAMOUFLAGE (Rhombic) (19397) 191228-0001	31E	EA	1
3	1080-01-475-1596	CASE, Carrying (Screen System) (19397) 184093-0003	31E	EA	1
4	1080-01-475-1595	REPAIR KIT, Camouflage Net Set (19397) 191262-0001	31E	EA	1



(1) ILLUS NUMBER	(2) NATIONAL STOCK NUMBER	(3) DESCRIPTION, CAGEC, AND PART NUMBER	(4) USABLE ON CODE	(5) U/M	(6) QTY RQR
Detail A	8305-01-475-1597	CLOTH, Camouflage (Desert R/S) (25 SQ FT) (19397) 191230-0001	31E	EA	1
Detail A	1080-01-497-9333	CASE, Carrying (Repair Kit) (19397) 184091-0002	31E	EA	1
	1080-01-475-1583	CAMOUFLAGE SCREENING SYSTEM (Class 2 – Desert, Type III R/T) (19397) 191233-0001	31F	EA	1
1	1080-01-475-1584	SCREEN, CAMOUFLAGE (Hexagon) (19397) 191234-0001	31F	EA	1
2	1080-01-475-1479	SCREEN, CAMOUFLAGE (Rhombic) (19397) 191235-0001	31F	EA	1
3	1080-01-475-1585	CASE, Carrying (Screen System) (19397) 184093-0004	31F	EA	1
4	1080-01-475-1586	REPAIR KIT, Camouflage Net Set (19397) 191236-0001	31F	EA	1
Detail A	8305-01-475-5250	CLOTH, Camouflage (Desert R/T) (25 SQ FT) (19397) 191237-0001	31F	EA	1
Detail A	1080-01-497-9334	CASE, Carrying (Repair Kit) (19397) 184091-0004	31F	EA	1
	1080-01-463-0046	SUPPORT, CAMOUFLAGE SCREENING SYSTEM (19397) 186312-0001	All	EA	1
Detail A	1080-01-462-3602	STRAP, Tiedown (Plastic) (300 EA) (19397) 186306-0001	All	EA	1
5	1080-01-461-0153	CASE, Carrying (Support System for Woodland and Desert)	All	EA	1
6	1080-00-108-1654	STAKE, Camouflage, Aluminum (19397) 13227E0136	All	EA	24
7	8105-01-464-3148	BAG, Textile ( Stakes) (19397) 186305-0001	All	EA	1
8	1080-01-464-8288	POLE, Support (Woodland and Desert) (19397) 184055-0001	All	EA	12
9	1080-01-461-0152	SHAPE DISRUPTER (Woodland and Desert) (19397) 184054-0001	All	EA	6

Section III. BASIC ISSUE ITEMS LIST

(1) ITEM NUMBER	(2) NATIONAL STOCK NUMBER	(3) DESCRIPTION	(4) U/M	(5) QTY
	N/A	Technical Manual TM 5-1080-250-12&P  <b>NOTE</b>  A Technical Manual is issued with each screen system.	EA	1

**APPENDIX E**

**ADDITIONAL AUTHORIZATION LIST (AAL)**

**SECTION I. INTRODUCTION**

**E-1. SCOPE.**

This appendix lists additional items you are authorized for the support of ULCANS.

**E-2. GENERAL.**

This list identifies items that do not have to accompany ULCANS and that do not have to be turned in with it. These items are all authorized to you by CTA, MTOE, TDA, or JTA.

**E-3. EXPLANATION OF COLUMNS IN THE AAL.**

Column (1) — National Stock Number (NSN). Identifies the stock number of the item to be used for requisitioning purposes.

Column (2) — Description, Commercial and Government Entity Code (CAGEC), and Part Number (P/N). Identifies the Federal item name (in all capital letters) followed by a minimum description when needed. The last line below the description is the CAGEC (in parentheses) and the part number.

Column (3) — Usable On Code. When applicable, gives you a code if the item you need is not the same for different models of equipment (Not applicable).

Column (4) — Unit of Measure (U/M). Indicates the physical measurement or count of the item as issued per the National Stock Number shown in column (1).

Column (5) — Qty Recm. Indicates the quantity recommended.

**Section II. ADDITIONAL AUTHORIZATION LIST**

(1) NATIONAL STOCK NUMBER	(2) DESCRIPTION, CAGEC, AND PART NUMBER	(3) USABLE ON CODE	(4) U/M	(5) QTY RECM
5110-00-241-9151	FILE, Hand (10001) 41F941	All	EA	1
5120-00-903-9303	HAMMER, Hand, Blacksmith's, Cross-Peen 2.5 lb. Hd. Wt., Non-sparking and Non-magnetic (01DJ4) H-41	All	EA	1
5110-01-451-4945	TOOL, Multipurpose, Folding, Pocket (0RAU7) 07542	All	EA	1
8415-00-268-7869	GLOVES, Men's and Women's (81349) MIL-G-2366	All	PR	4

Section II. ADDITIONAL AUTHORIZATION LIST - Continued

(1) NATIONAL STOCK NUMBER	(2) DESCRIPTION, CAGEC, AND PART NUMBER	(3) USABLE ON CODE	(4) U/M	(5) QTY RECM
4240-00-052-3776	GOGGLES, Industrial (80204) ANSI Z87.1	All	EA	4
8340-00-261-9750	Pin, Tent, Wood, 16 Inch (81349) MIL-P-2383	All	EA	24
8340-00-261-9751	Pin, Tent, Wood, 24 Inch (81349) MIL-P-2383	All	EA	24
8340-00-823-7451	Pin, Tent, Steel, Type II, 12 Inch (81349) MIL-P-501	All	EA	24
8340-00-985-7461	Pin, Tent, Steel, Type III, 18 Inch (81349) MIL-P-501	All	EA	24

**APPENDIX F**

**EXPENDABLE AND DURABLE ITEMS LIST**

**Section I. INTRODUCTION**

**F-1. SCOPE.**

This appendix lists expendable and durable items that you will need to operate and maintain the ULCANS. This list is for information only and is not authority to requisition the listed items. These items are authorized to you by CTA 50-970, Expendable/Durable items (except Medical, Class V, Repair Parts, and Heraldic items), or CTA 8-100, Army Medical Department Expendable/Durable items.

**F-2. EXPLANATION OF COLUMNS.**

Column (1) — Item Number. This number is assigned to the entry in the list and is referenced in the narrative instructions to identify the item.

Column (2) — Level. This column identifies the lowest level of maintenance that requires the listed item: C = Operator/Crew

Column (3) — National Stock Number (NSN). This is the NSN assigned to the item which you can use to requisition it.

Column (4) — Item Name, Description, Commercial and Government Entity Code (CAGEC), and Part Number (P/N). This column provides the other information you need to identify the item.

Column (5) — Unit of Measure (U/M). This code shows the physical measurement or count of an item, such as gallon, dozen, gross, etc."

**Section II. EXPENDABLE AND DURABLE ITEMS LIST**

(1) ITEM NUMBER	(2) LEVEL	(3) NATIONAL STOCK NUMBER	(4) ITEM NAME, DESCRIPTION, CAGE, PART NUMBER	(5) U/M
1	C	1080-01-062-2184	Shuttle, Twine, 30 Yards (For Woodland) Color No. 34088 (33996) 1100-1-5-STPP	EA
2	C	1080-01-060-1698	Shuttle, Twine, 30 Yards (For Desert) Color No. 30277 (33996) 1100-1-5-STPD	EA
3	C	4020-00-641-8899	Rope, Fibrous (Polyamide Nylon), Circum: 1.125 in. nominal; Color, Natural (81349) MIL-R-17343	REEL

**GLOSSARY**

Anchor Stakes	Aluminum stakes used to hold ULCANS to the ground.
Becket, Becket Loop	Loops of varying size located on the outer edges of screens; interwoven/tied to join screens together.
Cable Tie	Synonymous with strap, tiedown and tie wrap.
CAGE Code	Commercial and Government Entity (CAGE) Code. A five-digit, numeric code which is used to identify the manufacturer, distributor, Government agency, etc., that supplies the item.
Camouflage Screen	A single hexagon or rhombic (diamond-shaped) screen.
EIC	End Item Code
Garnish	Top side of camouflage material assembled with underside netting material creating a camouflage screen.
Net	Synonymous with screen in this document.
Netting	Bottom side camouflage material assembled with the top side garnish material to create a camouflage screen.
MAC	Maintenance Allocation Chart.
Modular Camouflage Screen System	Consists of 1 hexagon screen and 1 rhombic (diamond-shaped) screen.
Module	A hexagon and rhombic screen unit.
Multiple Screen System	Consists of one or more connected modular camouflage screen systems of any shape. Screens in a system must be of the same type (transparent or radar scattering)
PMCS	Preventive Maintenance Checks and Services
Radar Scattering Screen	ULCANS screen with radar scattering elements in the garnish material and base fabric
Radar Transparent Screen	ULCANS screen without radar scattering elements

**TM 5-1080-250-12&P**

Repair Kit	The kit used to make field repairs to return the ULCANS to a serviceable condition.
Screen	A single hexagon or rhombic (diamond-shaped) screen.
Screen Identification Tags	Tags located on two corners of each rhombic module or three corners of each hexagon module to identify type of screen (transparent or radar scattering)
Shape Disrupters	Circular plates placed on tops of support poles to distort camouflage screens into an irregular shape.
Strap, Tiedown	Plastic strip with locking device used for securing components and temporary repairs of camouflage screens, stake and Becket loops, cables, etc. Also referred to as cable tie and tie wrap.
Support Poles	Sectional aluminum poles used to support deployed ULCANS
Support System	Support poles, anchor stakes, and shape disrupters used to support the deployed ULCANS
ULCANS	Ultralightweight Camouflage Net System

ALPHABETICAL INDEX

<b>Subject</b>	<b>Page</b>
Abbreviations (RPSTL).....	C-6
Additional Authorization List (AAL).....	E-1
Administrative Storage.....	1-2
Camouflage Screening System (Figure C-2).....	C-10
Classification, Camouflage Screening Types and Class.....	1-11
Classification, Type, Class, and Frequency.....	1-11
Component of End Item and Basic Issue Items List (COEIL and BII) .....	D-1
Consolidated Index of Army Publications and Blank Forms .....	1-1
Cool Down Period.....	2-2
Cross Reference Index - National Stock Number Index.....	C-17
Cross Reference Index - Part Number Index.....	C-18
Deployment Checks .....	2-15
Deployment Instructions .....	2-1
Deployment/Retrieval/Storage Instructions, ULCANS (Figure 2-2) (Sheet 1 of 9) .....	2-5
Deployment/Retrieval/Storage Instructions, ULCANS (Figure 2-2) (Sheet 2 of 9) .....	2-6
Deployment/Retrieval/Storage Instructions, ULCANS (Figure 2-2) (Sheet 3 of 9) .....	2-7
Deployment/Retrieval/Storage Instructions, ULCANS (Figure 2-2) (Sheet 4 of 9) .....	2-8
Deployment/Retrieval/Storage Instructions, ULCANS (Figure 2-2) (Sheet 5 of 9) .....	2-9
Deployment/Retrieval/Storage Instructions, ULCANS (Figure 2-2) (Sheet 6 of 9) .....	2-10
Deployment/Retrieval/Storage Instructions, ULCANS (Figure 2-2) (Sheet 7 of 9) .....	2-11
Deployment/Retrieval/Storage Instructions, ULCANS (Figure 2-2) (Sheet 8 of 9) .....	2-12
Deployment/Retrieval/Storage Instructions, ULCANS (Figure 2-2) (Sheet 9 of 9) .....	2-13
Destruction of Army Materiel .....	1-2
Doorway Entry/Egress (Figure 2-3) .....	2-16
Emergency Retrieval .....	2-18
Equipment Description .....	1-2
Expendable and Durable Items List.....	F-1
Explanation of Column in the MAC, Section II .....	B-3
Explanation of Columns (COEIL and BII) .....	D-1
Explanation of Columns (Sections II and III) (RPSTL).....	C-1
Explanation of Columns in the AAL .....	E-1
Explanation of Columns in the Remarks, Section VI (MAC) .....	B-4
Explanation of Columns in the Tool and Test Equipment Requirements, Section III (MAC) .....	B-4
Explanation of the Index Format and Columns (Section IV) (RPSTL) .....	C-5
Folding Instructions, ULCANS .....	2-16
Forms .....	A-1
Genera.....	2-1
General (AAL) .....	E-1
General (COEIL and BII) .....	D-1
General (RPSTL).....	C-1
Glossary.....	Glossary-1
Height of Support Poles (Table 1-4) .....	1-12
How to Locate Repair Parts .....	C-6
Inclement Weather .....	2-18
Maintenance Allocation Chart.....	B-5
Maintenance Forms, Records, and Reports .....	1-1
Maintenance Functions.....	B-1
Miscellaneous Publications .....	A-1
Modular Camouflage Screen System .....	1-2
Module Determination Chart.....	1-8
Module Determination Chart (Figure 1-5).....	1-9
Multiple Screen Assembly .....	2-3
Multiple Screen Assembly and Disassembly Instructions (Figure 2-1) .....	2-4



ALPHABETICAL INDEX

Subject	Page
Normal Retrieval .....	2-16
Number of Support System Components (Table 1-3) .....	1-12
Operating Under Unusual Conditions .....	2-18
Position of Screen Identification Tags (Figure 1-5) .....	1-13
Positioning Support Poles .....	2-13
Purpose of Equipment .....	1-1
Radar Transparent and Radar Scattering Screen Identification Tags (Figure 1-6) .....	1-14
References .....	A-1
Repair Kit .....	1-2
Repair Kit, Camouflage Net Set (Figure C-4) .....	C-14
Repair Parts and Special Tools List .....	C-1
Repair Requirements .....	3-1
Reporting Equipment Improvement Recommendations .....	1-2
Reporting of Item and Packaging Discrepancies .....	1-2
Reports of Maintenance and Unsatisfactory Equipment .....	1-1
Retrieval Instructions, Multiple Screen Configuration .....	2-16
Roll Method for Multiple Screens .....	2-17
Scope (System) .....	1-1
Scope (AAL) .....	E-1
Scope (COEIL and BII) .....	D-1
Scope (Expendable and Durable Items) .....	F-1
Scope (References) .....	A-1
Scope (RPSTL) .....	C-1
Screen Configuration Data (Figure 1-4) .....	1-7
Screen Configuration Dimensions (Table 1-1) .....	1-8
Screen Maintenance Procedures .....	3-1
Shape Disrupter Assemblies .....	1-3
Shape Disruption .....	2-3
Special Assembly Instructions .....	2-14
Special Information .....	C-5
Special Tools .....	2-17
Stakes .....	2-14
Support Poles .....	2-13
Support System .....	1-3
Support, Camouflage Screening System (Figure C-3) .....	C-12
Tabulated Data .....	1-10
Technical Manuals .....	A-1
The Army Maintenance System MAC .....	B-1
Total System Weight (Table 1-2) .....	1-11
Transportation Discrepancy Report .....	1-2
Typical ULCANS Applications (Figure 1-3, Sheet 1 of 2) .....	1-5
Typical ULCANS Applications (Figure 1-3, Sheet 2 of 2) .....	1-6
ULCANS (Class 1 - Woodland and Class 2 - Desert, Type IV (Gp-R/S) and Type III (Gp-R/T)) (Figure C-1) .....	C-8
ULCANS Applications and Configuration Data .....	1-3
ULCANS Camouflage Screen Repair (Figure 3-1) (Sheet 1 of 2) .....	3-3
ULCANS Camouflage Screen Repair (Figure 3-1) (Sheet 2 of 2) .....	3-4
ULCANS Components (Figure 1-2) .....	1-3
ULCANS Components, Group 00 (Figure D-1) .....	D-3
ULCANS Deployment .....	2-2
ULCANS Entry/Egress Doorway .....	2-15
Ultralightweight Camouflage Net Systems (ULCANS) (Figure 1-1) .....	1-1
Volatile Fuels and Hazardous Materials .....	2-15

**SOMETHING WRONG WITH THIS PUBLICATION**



THEN ... JOT DOWN THE INFO ABOUT IT ON THIS FORM. CAREFULLY TEAR IT OUT. FOLD IT AND DROP IT IN THE MAIL.

FROM: (PRINT YOUR UNIT'S COMPLETE ADDRESS)  
 Commander  
 Stateside Army Depot  
 ATTN: AMSTA-US  
 Stateside, N.J. 07703-5007

---

DATE SENT  
 10 July 1975

PUBLICATION NUMBER TM 11-5840-340-20	PUBLICATION DATE 23 Jan 74	PUBLICATION TITLE Radar Set AN/PRC-76
---	-------------------------------	--

BE EXACT. PIN-POINT WHERE IT IS				IN THIS SPACE TELL WHAT IS WRONG AND WHAT SHOULD BE DONE ABOUT IT:
PAGE NO	PARA GRAPH	FIGURE NO	TABLE NO	
2-25	2-28			<p>Recommend that the installation antenna alignment procedure be changed throughout to specify a 20 IFF antenna lag rather than 10.</p> <p>REASON: Experience has shown that with only a 10 lag, the antenna servo system is too sensitive to wind gusting in excess of 25 knots, and has a tendency to rapidly accelerate and decelerate as it hunts, causing strain to the drive train. Hunting is minimized by adjusting the lag to 20 without degradation of operation.</p>
3-10	3-3		3-1	<p>Item 5, Functional control. Change "2 dB" to "3 dB".</p> <p>REASON: The adjustment procedure for the TRANS POWER FAULT indicator calls for a 3 dB (500 watts) adjustment to light the TRANS POWER FAULT indicator.</p>
5-6	5-8			<p>Add new step 1.1 to read, "Replace cover plate removed in step 1.1, above."</p> <p>REASON: To replace the cover plate.</p>
		FO-3		<p>Zone C 3. On J1-2, change "+24 VDC" to "+5 VDC".</p> <p>REASON: This is the output line of the 5 VDC power supply. +24 VDC is the input voltage.</p>

TEAR ALONG DOTTED LINE

PRINTED NAME, GRADE OR TITLE AND TELEPHONE NUMBER SSG I. M. DeSpirito 999-1776	SIGN HERE 
---	---------------

FILL IN YOUR  
UNIT'S ADDRESS

FOLD BACK

DEPARTMENT OF THE ARMY

\_\_\_\_\_  
\_\_\_\_\_

OFFICIAL BUSINESS

PLEASE  
AFFIX  
STAMP  
POSTAGE  
REQUIRED

**SAMPLE**

Commander  
U.S. Army Communications-Electronics Command  
and Fort Monmouth  
ATTN: AMSEL-LC-LEO-D-CS-CFO  
Fort Monmouth, New Jersey 07703-5006

TEAR ALONG DOTTED LINE

# SOMETHING WRONG WITH THIS PUBLICATION

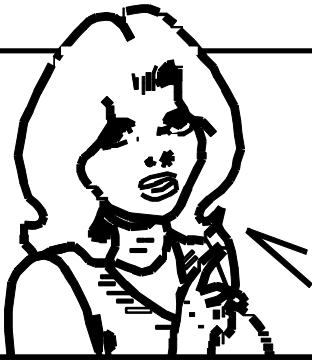

*THEN ... JOT DOWN THE INFO ABOUT IT ON THIS FORM. CAREFULLY TEAR IT OUT. FOLD IT AND DROP IT IN THE MAIL.*

FROM: (PRINT YOUR UNIT'S COMPLETE ADDRESS)

DATE SENT

PUBLICATION NUMBER

PUBLICATION DATE

PUBLICATION TITLE

BE EXACT PIN-POINT WHERE IT IS

IN THIS SPACE TELL WHAT IS WRONG AND WHAT SHOULD BE DONE ABOUT IT:

PAGE NO

PARA GRAPH

FIGURE NO

TABLE NO

TEAR ALONG DOTTED LINE

PRINTED NAME, GRADE OR TITLE AND TELEPHONE NUMBER

SIGN HERE

FILL IN YOUR  
UNIT'S ADDRESS

FOLD BACK

DEPARTMENT OF THE ARMY



OFFICIAL BUSINESS

PLEASE  
AFFIX  
STAMP  
POSTAGE  
REQUIRED

TEAR ALONG DOTTED LINE

**Commander**  
**U.S. Army Communications-Electronics Command**  
**and Fort Monmouth**  
**ATTN: AMSEL-LC-LEO-D-CS-CFO**  
**Fort Monmouth, New Jersey 07703-5006**

# SOMETHING WRONG WITH THIS PUBLICATION



*THEN ... JOT DOWN THE INFO ABOUT IT ON THIS FORM. CAREFULLY TEAR IT OUT. FOLD IT AND DROP IT IN THE MAIL.*

FROM: (PRINT YOUR UNIT'S COMPLETE ADDRESS)

DATE SENT

PUBLICATION NUMBER

PUBLICATION DATE

PUBLICATION TITLE

BE EXACT PIN-POINT WHERE IT IS

IN THIS SPACE TELL WHAT IS WRONG AND WHAT SHOULD BE DONE ABOUT IT:

PAGE NO

PARA GRAPH

FIGURE NO

TABLE NO

TEAR ALONG DOTTED LINE

PRINTED NAME, GRADE OR TITLE AND TELEPHONE NUMBER

SIGN HERE

FILL IN YOUR  
UNIT'S ADDRESS

FOLD BACK

DEPARTMENT OF THE ARMY



OFFICIAL BUSINESS

PLEASE  
AFFIX  
STAMP  
POSTAGE  
REQUIRED

TEAR ALONG DOTTED LINE

**Commander**  
**U.S. Army Communications-Electronics Command**  
**and Fort Monmouth**  
**ATTN: AMSEL-LC-LEO-D-CS-CFO**  
**Fort Monmouth, New Jersey 07703-5006**

# SOMETHING WRONG WITH THIS PUBLICATION



*THEN ... JOT DOWN THE INFO ABOUT IT ON THIS FORM. CAREFULLY TEAR IT OUT. FOLD IT AND DROP IT IN THE MAIL.*

FROM: (PRINT YOUR UNIT'S COMPLETE ADDRESS)

DATE SENT

PUBLICATION NUMBER

PUBLICATION DATE

PUBLICATION TITLE

BE EXACT PIN-POINT WHERE IT IS

IN THIS SPACE TELL WHAT IS WRONG AND WHAT SHOULD BE DONE ABOUT IT:

PAGE NO

PARA GRAPH

FIGURE NO

TABLE NO

TEAR ALONG DOTTED LINE

PRINTED NAME, GRADE OR TITLE AND TELEPHONE NUMBER

SIGN HERE



FILL IN YOUR  
UNIT'S ADDRESS

FOLD BACK

DEPARTMENT OF THE ARMY



OFFICIAL BUSINESS

PLEASE  
AFFIX  
STAMP  
POSTAGE  
REQUIRED

TEAR ALONG DOTTED LINE

**Commander**  
**U.S. Army Communications-Electronics Command**  
**and Fort Monmouth**  
**ATTN: AMSEL-LC-LEO-D-CS-CFO**  
**Fort Monmouth, New Jersey 07703-5006**

By Order of the Secretary  
of the Army:

ERIC K. SHINSEKI  
*General, United States Army*  
*Chief of Staff*

Official:

  
JOEL B. HUDSON  
*Administrative Assistant to the*  
*Secretary of the Army*  
0233603

DISTRIBUTION:

To be distributed in accordance with the initial distribution number  
(IDN) 256761 requirements for TM 5-1080-250-12&P

